

**Sentek**<sup>™</sup>  
technologies

# Sentek<sup>™</sup> PLUS



**HARDWARE MANUAL**

**VERSION 2.0**

*All rights reserved.* No part of this document may be reproduced, transcribed, translated into any language or transmitted in any form electronic or mechanical for any purpose whatsoever without the prior written consent of **Sentek Pty Ltd**. All intellectual and property rights remain with **Sentek Pty Ltd**.

All information presented is subject to change without notice.

**Ó 2005-2012 Sentek Pty Ltd**

*Sentek™, EnviroSCAN™, EnviroSMART™, EasyAG™, TriSCAN™ and Irrimax™ are trademarks or registered trademarks of Sentek Pty Ltd that may be registered in one or more jurisdictions.*

*Scotchlok® is a registered trademark of 3M.*

**Sentek Pty Ltd**

A.C.N. 007 916 672

77 Magill Road

Stepney, South Australia 5069

**Phone:** +61 8 8366 1900

**Facsimile:** +61 8 8362 8400

Internet: [www.sentek.com.au](http://www.sentek.com.au)

Email: [sentek@sentek.com.au](mailto:sentek@sentek.com.au)

Rev 2.0 (2012-03-07)

# SENTEK PLUS - STATEMENTS OF COMPLIANCE

---

## FCC NOTE OF COMPLIANCE AND STATEMENT OF LIABILITY

---

### Electro-Magnetic Compliance

This equipment has been tested and found to comply with the limits for a Class B digital device, pursuant to part 15 of the FCC rules. These limits are designed to provide reasonable protection against harmful interference in a residential installation. This equipment generates, uses and can radiate radio frequency energy and, if not installed and used in accordance with the instructions, may cause harmful interference to radio communications. However, there is no guarantee that interference will not occur in a particular installation. If this equipment does cause harmful interference to radio or television reception, which can be determined by turning the equipment off and on, the user is encouraged to try to correct the interference by one or more of the following measures:

- Reorientation or relocation of the receiving antenna.
- Connection of the equipment into an outlet on a circuit different from that to which the receiver is connected.
- Consultation with the dealer or an experienced radio/TV technician.

### EMC approvals

---

The Sentek PLUS system complies with "EN61326:1997 Amdt 1:1998 Amdt 2:2001 Amdt 3:2003 EMC standard for equipment for measurement, control and laboratory use".

The equipment complies with the following specifications:

- FCC Part 15 Class B.
- EN55011:1998, Amendment 1:1999 (Radiated and conducted emissions)
- EN61000-4-2:1995 (Immunity to Electrostatic Discharge (ESD))
- EN61000-4-3:2002 (Immunity to Radiated Fields (RF))
- EN61000-4-4:1995 (Immunity to Electrical Fast Transients (EFT))
- EN61000-4-5:1995 (Immunity to Surges)
- EN61000-4-6:1996 (Immunity to Conducted RF)

### Marking

---

The above EMC approvals allow the product to be marked CE, C-tick and FCC.

### Modifications

---

Any modifications to any part of the equipment or to any peripherals may void the EMC compliance of the equipment.

### Radio Interference

---

The probe is not to be operated in free air as it may cause interference to radio communication devices

# TABLE OF CONTENTS

---

<b>Sentek PLUS - Statements of Compliance</b> .....	<b>ii</b>
FCC note of compliance and statement of liability.....	ii
EMC approvals.....	ii
Marking.....	ii
Modifications.....	ii
Radio Interference.....	ii
<b>Sentek PLUS Introduction</b> .....	<b>1</b>
Background.....	1
Features.....	1
CDMA Support.....	2
Hardware Requirement Lists For Sentek PLUS.....	2
Required parts to assemble a complete System.....	2
Referenced Documents.....	4
<b>System Setup</b> .....	<b>5</b>
Introduction.....	5
Data Transfer and Hosting.....	5
Buying a SIM card and data packet plan for modem.....	5
Hosting Set-up and Recommendations.....	6
Sentek PLUS DTU.....	8
Sentek PLUS Probes.....	10
Introduction.....	10
Assemble and Normalise.....	10
Install access tube and the probe.....	10
Cable probe to DTU.....	15
Probe Configuration.....	16
Modem Configuration.....	21
Testing.....	22
Viewing Data.....	23
Downloading.....	23
Viewing.....	24
<b>Maintenance</b> .....	<b>25</b>
DTU.....	25
Probe.....	25
Solar Panel.....	25
Cabling.....	25
SLA battery.....	25
Probe Cable Connector.....	25
<b>Firmware and board type</b> .....	<b>27</b>
Board Type.....	27
Firmware.....	27
<b>Appendix A – Modem information</b> .....	<b>29</b>
Compatible Modems.....	29
ETM Pacific ETM9800 modem.....	29
SIM Card Pin codes.....	29
Useful AT Commands.....	29
Extra Frequency Band information.....	31
Older Sentek PLUS Systems.....	32
Parity.....	32
TCP/IP Stack.....	32
APN server.....	32
<b>Appendix B – Network page explained</b> .....	<b>33</b>

<b>Appendix C – Upload Operation Diagram.....</b>	<b>34</b>
<b>Appendix D - Estimated Battery Life with no Solar Panel .....</b>	<b>35</b>
Calculating the Battery Life.....	35
<b>Appendix E – PConfig Response Fields .....</b>	<b>37</b>
Last Response .....	37
Test/Upload Result Codes.....	37
Upload log.....	38
<b>Appendix F - Technical Specifications.....</b>	<b>39</b>
EnviroSCAN Series II 232 interface .....	39
EasyAG Series II RS232 Interface.....	40
<b>Appendix G - Glossary of Terms .....</b>	<b>42</b>
<b>Appendix H - Sentek Plus Quick Reference Guide .....</b>	<b>43</b>
Product Set-up Checklist .....	43
Preparation.....	43
Field Installation .....	43
Software.....	44
Troubleshooting Guide .....	45
Recommended Maintenance Schedules.....	48
6 months (or each time access tube is opened) .....	48
12 months .....	48
3 years .....	48

## TABLE OF FIGURES

---

Figure 1 Block Diagram of the Sentek PLUS in use.....	1
Figure 2 Completed system block diagram.....	3
Figure 3 Sentek PLUS front panel layout .....	4
Figure 4 Sentek PLUS DTU housing.....	8
Figure 5 Rear of Sentek PLUS Front panel showing charger and Modem layout .....	9
Figure 6 Modem power cable connections .....	9
Figure 7 EnviroSCAN sensor addressing.....	10
Figure 8 EasyAG PLUS interface and wiring diagram .....	11
Figure 9 EnviroSCAN interface and wiring diagram.....	11
Figure 10 Probe sitting correctly in tube with connector in place.....	12
Figure 11 Gel bag.....	12
Figure 12 Flat Cap interface wiring .....	12
Figure 13 Silica gel bag placement .....	13
Figure 14 Sentek PLUS Probe Cable Connector (Probe cable side).....	13
Figure 15 Removing Contact Insert.....	13
Figure 16 Inserting cable through Gland Nut.....	14
Figure 17 Trimming wires .....	14
Figure 18 Contact Insert Screw Terminals .....	14
Figure 19 Flat edges.....	15

Figure 20 Sealing gland end .....	15
Figure 21 Cable joined using Scotchlocks.....	15
Figure 22 PConfig connected to probe with default settings .....	16
Figure 23 Auto-detected sensors .....	17
Figure 24 Setting depths.....	17
Figure 25 Air counts and then Water counts.....	18
Figure 26 Clock page.....	18
Figure 27 Edit screen.....	19
Figure 28 Completed Logger page.....	20
Figure 29 Network settings (with no unwritten changes).....	21
Figure 30 Power settings .....	21
Figure 31 Sending modem settings (Response from a Fastrack modem shown above). 22	
Figure 32 Sensor testing.....	23
Figure 33 Successful Test .....	23
Figure 34 EnviroSCAN RS232 logging interface .....	27
Figure 35 EasyAG RS232 logging interface .....	27
Figure 36 Checking probe type and firmware versions .....	28
Figure 37 Upload result codes from most recent upload attempt .....	37
Figure 38 EnviroSCAN RS232 probe interface board layout.....	40
Figure 39 EasyAG Series II RS232 probe interface board layout.....	41
Figure 40 Sentek EnviroSCAN PLUS interface wiring .....	43
Figure 41 Sentek EasyAG PLUS interface wiring .....	44







## SENTEK PLUS INTRODUCTION

---

### BACKGROUND

---

Sentek PLUS combines the scientifically and commercially proven sensor technology of EnviroSCAN, with web enabled, wireless communication.

In addition to this, Sentek PLUS also has the ability to continuously track fertilizer / salinity data through the use of TriSCAN sensors. Sentek PLUS can utilise GPRS or NextG communications to send soil water and fertilizer / salinity data from the probe to the users PC via the internet. Alternatively, it provides for direct in-field download when services become unavailable in regional areas.

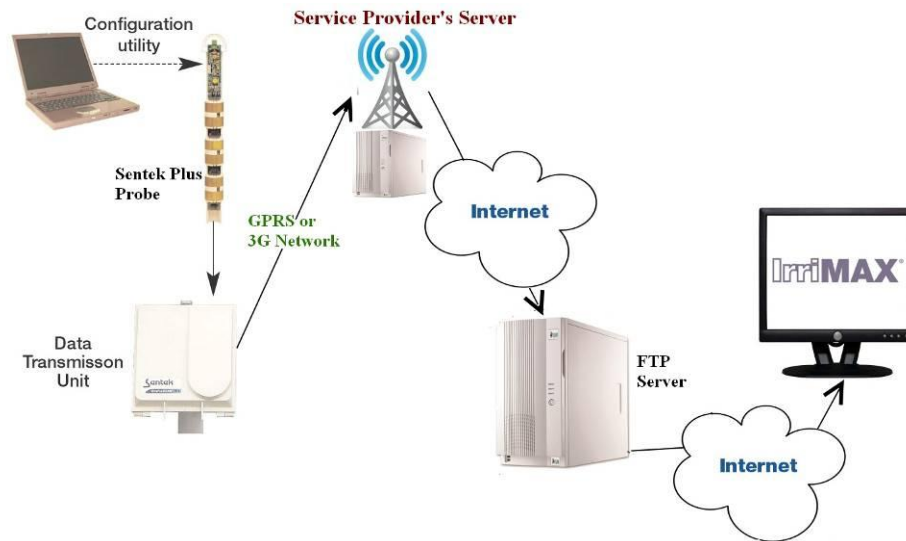

Figure 1 Block Diagram of the Sentek PLUS in use

### FEATURES

---

#### Sentek PLUS Probe

- Ø Utilises Sentek Soil Moisture & TriSCAN sensors, tubes and rod
- Ø Available in both EasyAG and EnviroSCAN probes
- Ø Interface can store over 2000 samples (~21 days @ 15 minute sampling intervals)

#### Sentek PLUS Data Transmission Unit (DTU)

- Ø Sentek PLUS Probe is connected to the DTU via 5 metres of cable
- Ø An assembled Sentek PLUS DTU comprises:
  - GPRS or NextG Communication Module
  - Antenna
  - 12-volt battery, with solar charger board
- Ø Facilitates direct communication from Sentek PLUS probe to a server computer via the Internet

#### Sentek PLUS with IriMAX software suite

- Ø Seamless download via Internet with Sentek IriMAX Software
- Ø Dial in feature allows probe settings to be changed remotely
- Ø Network feature allows flexible modem configuration
- Ø Webify and Email functions allow data to be emailed or viewed online as html pages

### Sentek PLUS Serial Connection (Front Panel Download)

As an alternative to downloading using the Internet, it is also possible to download by directly connecting your computer to the front panel connector on the Sentek PLUS Data Transmission Unit (DTU). This is typically done with a portable computer. For further information on how to do this please refer to the Data Exchange manual.

### CDMA Support

---

The Australian CDMA network has been shutdown. Consequently there is no longer a CDMA modem certified by Sentek for use with Sentek PLUS systems.

Sentek PLUS systems, with probe firmware version 1.2.3 or later, should work with CDMA modems provided they are in an area with CDMA network access and Probe Configuration Utility Network tab has been appropriately setup.

For further information about using existing CDMA units see "EnviroSCAN Plus NextG CDMA Upgrade Guide".

## HARDWARE REQUIREMENT LISTS FOR SENTEK PLUS

---

### Required parts to assemble a complete System

---

- Sentek PLUS front panel and DTU housing
- 12V 7.5 AH Sealed lead acid battery
- Mounting Pole
- 12V Solar Panel & Solar Panel Bracket
- Solar panel bird deterrer
- 5m Length of Data cable to connect the probe (with connector)
- Ferrite bead for cable
- Optional GPRS or NextG Modem
- Antenna with cable

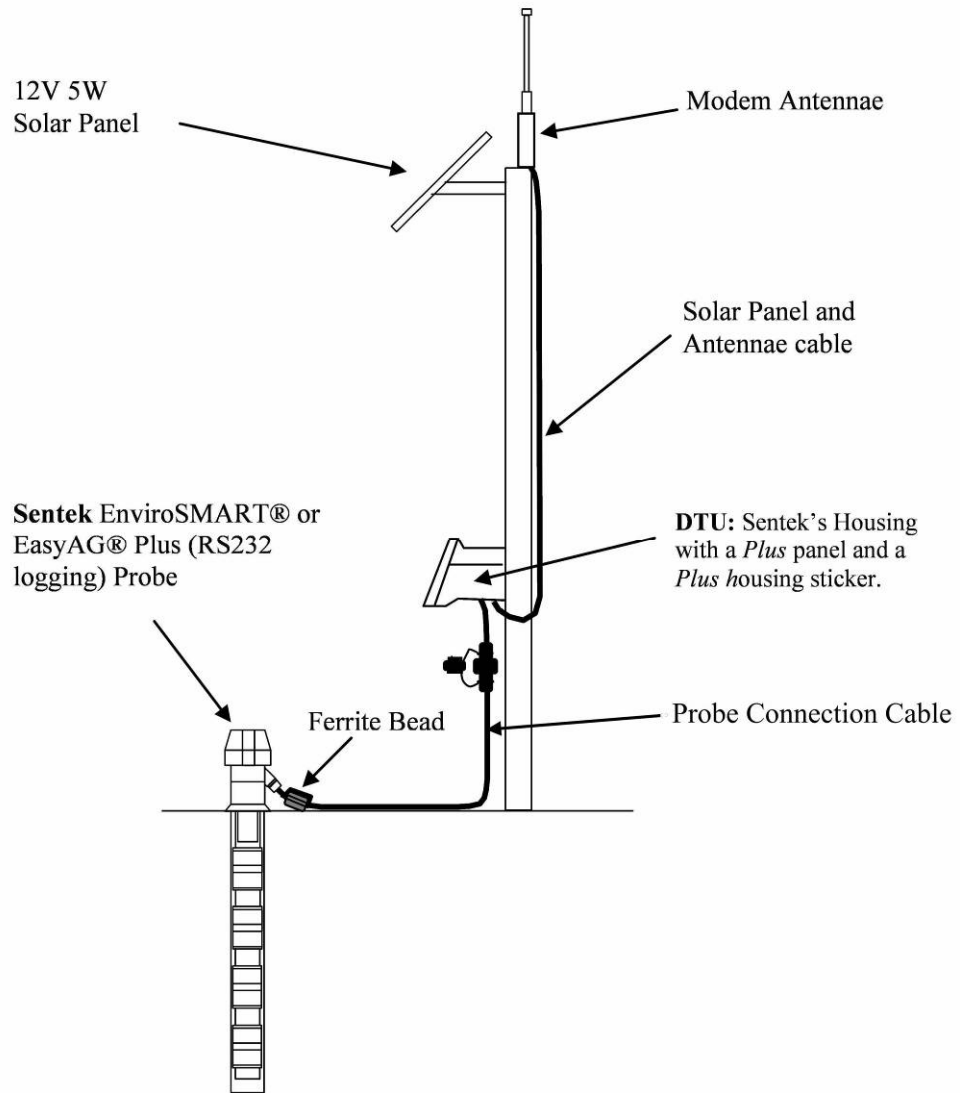

Figure 2 Completed system block diagram



Figure 3 Sentek PLUS front panel layout

#### Referenced Documents

---

- EasyAG Installation Guide
- Access Tube Installation Guide
- Irrimax 7.1 Data Exchange User Guide – Sentek PLUS Module
- Probe Configuration Utility Version 1.7.2 or later Manual
- Sentek Technical Brief - TB064-ESPlus NextG Fails Network Selection
- Sentek Technical Brief - TB065-ESPlus NextG SIM PIN
- EnviroSCAN Plus NextG CDMA Upgrade Guide
- EnviroSCAN FlatCap Training Presentation

## SYSTEM SETUP

---

### INTRODUCTION

---

Preparation, assembly and installation should generally be completed in the order of the steps in this section. Efficiencies might be gained by experienced installers altering the order of the steps taken.

For example; although the sensor normalisation and configuration process is described below in the section Probe Configuration, it is recommended that the probe be normalised, configured and tested prior to field installation. This will help ensure that all hardware and data transfer aspects of the system are working before installation begins.

### DATA TRANSFER AND HOSTING

---

**A Sentek PLUS probe must have access to the internet and somewhere to send its data to.** It needs a SIM card that will allow the modem to connect to the internet and a computer that is set up as an FTP server which can be accessed via the internet. The probe will make a connection to the internet at each upload interval, log in to the FTP server and copy the data files to the computer directory specified.

**Note:** The internet access and FTP server should be set up prior to assembling and installing the hardware.

#### Buying a SIM card and data packet plan for modem

---

Each Sentek PLUS system will require a SIM card for the modem. This SIM card must have a data plan associated with it and must have reasonable coverage in the area where the probe will be installed. This data plan is similar to what is needed for accessing the internet on your mobile (cell) phone.

It is not necessary to get a plan with cheaper voice calls, SMS rates, voice mail options or other such features, as the probe will only use the data features of the plan, thus the GPRS or NextG data part of the plan must be the cheapest aspect.

For use of the Dial-in feature, the SIM card must have a data (CSD) number that can be called.

When sourcing the SIM card and data plan make certain of the factors detailed below:

##### No Session Fees

**Every time data is uploaded to the internet from the probe the network provider may charge what is called a session fee or flag fall. For systems uploading frequently this can become very expensive.**

A typical session fee is around 25 cents. If uploads occur every 3 hours (8 uploads/day) this would cost around \$60 per month, on top of data usage charges. Therefore, it is advised that a plan with no session fees be used.

##### Low Data Rates

To keep costs down, It is important when choosing a plan that you try to assess how much data you will be uploading, and how often you will be uploading it before choosing a plan accordingly.

Most data plans work in much the same way as a voice plan, costing a certain amount each month for a certain volume of data, and once this has been exceeded a charge for the excess data is applied.

Example plan:

- Ø Base cost of \$5 per month
- Ø No session fees
- Ø 2,000 KB included per month
- Ø 1 cent per excess KB

If 1,800 KB is used, this plan will cost \$5 per month, if however 2,200 KB is used in a month that month's usage will come to \$7.

A probe logging every 15 minutes and uploading every 90 minutes will use roughly 1,000 – 1,500 KB each month.

Uploading less often (which is recommended for power savings) will reduce data usage more than sampling less often (within certain limits), however a system that samples every 30 minutes, and uploads every 3 hours would transmit half as much data as the system described previously.

**Note:** Due to variable coverage, internet congestion or other circumstances, uploads may fail. The data will be available after the next successful upload, but in areas where these issues occur, more frequent uploads may help ensure that data is accessible when required.

As every upload has a fixed overhead containing configuration information, it is advisable to maximise the number of samples per upload to reduce data usage.

Table 1 Data Usage for different numbers of samples per upload

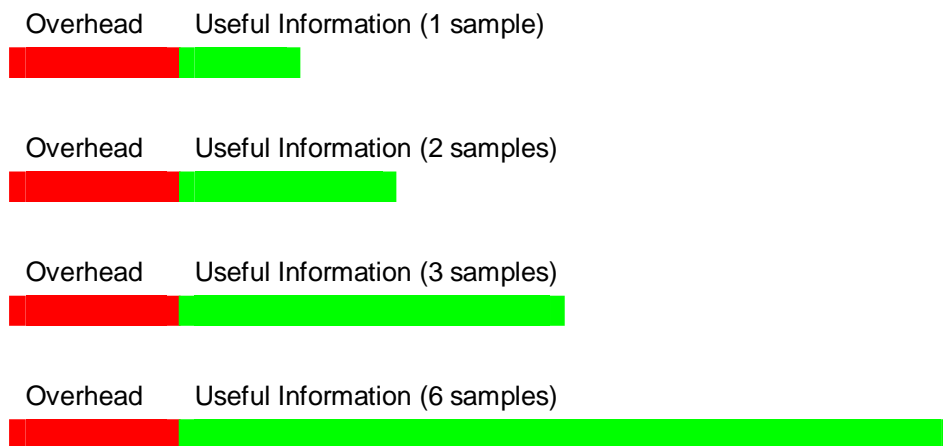

Naturally, the requirement for up-to-date data being available also needs to be considered. Generally, a good balance is to be found by uploading between two and four times a day. A probe which is set to sample every 15 minutes and upload twice a day should use no more than 1000 KB ( $\approx$ 1MB) per month.

The number of sensors on a probe has little effect on the amount of data being transferred. It should also be noted that because of the way the internet operates and the charging structures that telecommunication companies use, it is impossible to get an exact figure for the amount of data that will be sent, however, rough figures can be calculated using the above values.

#### Available Service

When choosing a service provider you should make certain that GPRS or NextG coverage is available in the area that you intend to install your system. It may also be useful to check the quality of service available. Unfortunately this is something that can only be determined using local knowledge, as service providers' estimates of their coverage are often overly optimistic, particularly in rural areas.

### Hosting Set-up and Recommendations

---

When choosing or setting up a web server, there are a number of requirements that should be considered. These are outlined below.

#### FTP Server

It is essential that the host server support FTP access using port 21. FTP is the protocol used by the probe to upload data to the internet and without it the system cannot function. Port 21 is standard for FTP on the internet, and very few servers do not use it.

#### Fixed Address

Because the probe stores the address of the server in its internal memory the address for the server must be fixed. The server address should be associated with a static IP address or a domain name as it is essential that the address does not change or the probe will need to be reconfigured each time a change occurs.

#### Supporting Multiple Users

It is important that a server supports multiple users connecting at a time. It is possible in the case of multiple probe owners that more than one probe will try to upload at once, or that one or more users may attempt to use IrriMAX Data Exchange to log on and download from the server whilst a probe is uploading.

Although uploads can be staggered using the sample origin setting (see section *Probe Configuration*), it is desirable that the chosen server can support multiple FTP sessions connected at one time and potentially more than one session at a time using the same log in username and password.

### File Storage Limits

Whilst the total amount of data uploaded by a single probe is not significant, there are a number of factors that may increase the required amount of storage well beyond what is expected.

A single probe is unlikely to upload more than 2000KB of data per month to be stored on the server. Data Exchange can be set to remove files older than a configurable number of days (the default is 90 days).

However, the cluster size of the server must be considered - this is the minimum size each file counts as on the hard disk. On most servers, this will be 4 or 8KB. This would mean, for example, that a directory containing 1500 files of 200 bytes each, would count for approximately 5.9MB on a server with a 4KB cluster size or 11.7MB on one with an 8KB cluster size, despite the total amount of data stored being less than 300KB. **A server may therefore require at least 20MB of storage space per probe, depending on configuration.**

The number of files allowed on a chosen FTP server may also cause problems. It is known that some servers restrict the total number of individual files to a maximum of around 50,000 or less, and many will truncate file lists at 2000 files.

A probe uploading every hour will produce 732 files in a month. Over 3 months, this amounts to around 2200 files. If the file list is truncated at 2000 files, even if Data Exchange is set to delete files older than 90 days, data from the most recent 8 days will appear to not be available to download, despite being on the server and the probe saying that it has been uploaded successfully.

### Domain Registration

**A static IP address can be used for the upload destination, but it is preferable to have an actual domain name.**

When choosing between using a domain name or IP address, consideration must be given to the fact that when using an IP address, a change of this address will result in probes and download settings needing to be reconfigured, often on site by a trained technician.

When a server is attached to the internet it is given what is called an IP address. An IP address is a unique number to identify a machine connected to the internet - for example the original Sentek FTP server at [ftp.enviroscanplus.com](http://ftp.enviroscanplus.com) had an IP address of 72.9.224.170, but this has now changed. Provided that it is static (i.e. permanently assigned to that server), it is possible to configure a Sentek PLUS system to upload to an IP address.

However, this can be difficult to remember and is prone to error. When choosing a server you should also ask the host company about registering a domain name for that server. This way when setting up probes and downloading data, a normal URL (web site address or name) can be used instead of an IP address.

### Data Allowance (Bandwidth)

Most web hosting agreements include a limit to the amount of data traffic (bandwidth) a server can receive during a month. Most companies offer around 500 MB a month as standard. Unless the server is hosting an extremely large number of probes, or is likely to have a large number of users downloading the data, this should be quite sufficient.

### Regular Backups

Whilst it is not essential, it is strongly recommended that the host of your FTP server has a good backup strategy. This should include daily backups and some form of off-site data store. All reliable hosting companies will have something like this.

### HTTP

Irrimax Data Exchange has the ability to retrieve a directory listing and download the probe files over HTTP.

The main advantage of downloading over HTTP is that it is generally a quicker when compared to FTP.

It should be noted that some servers, by default, do not enforce password protection for HTTP access, but can be configured with it. Also note that while some servers do not allow file alteration or deletion over HTTP, others do.

**Note:** FTP access is still required, as probes are only able to upload over FTP



HTTP is required for viewing Webified IrriMAX data. Having HTTP and FTP access to the server allows for it to be used for uploading and viewing of both probe and Webify data. For more information about Webify, see the IrriMAX Help.

### Where to Buy

Numerous web hosting providers are available that offer packages that are suitable for use with Sentek PLUS. Due to the nature of the internet it is not essential that the hosting company be based in your home country. Many US based companies offer very competitive deals.

Alternatively, with your own IT support you can set up your own server machine to host the data. Provide your IT support person with this section of the manual when asking them to set up the server.

## SENTEK PLUS DTU

1. Install the mounting pole close to the intended probe site and mount the DTU enclosure.
2. Mount the solar panel on the pole and pull the solar panel cable through the cable gland into the DTU. Screw the solar panel wires into the Front Panel solar panel connector and connect it to the Front Panel.

**Important:** Ensure Front Panel is switched off until all cabling connections have been completed. If unsure, connect battery and solar panel last, after the probe has been connected.

3. Mount the antenna on the solar panel bracket, insert the antenna cable into the DTU enclosure and fix the cable gland in place with the nut.
4. Connect the antenna to the modem.

**Warning: Potential equipment damage!** - Do not remove the ETM9XXX modem antenna lead from holder unless battery and solar panel are disconnected from the Front Panel.

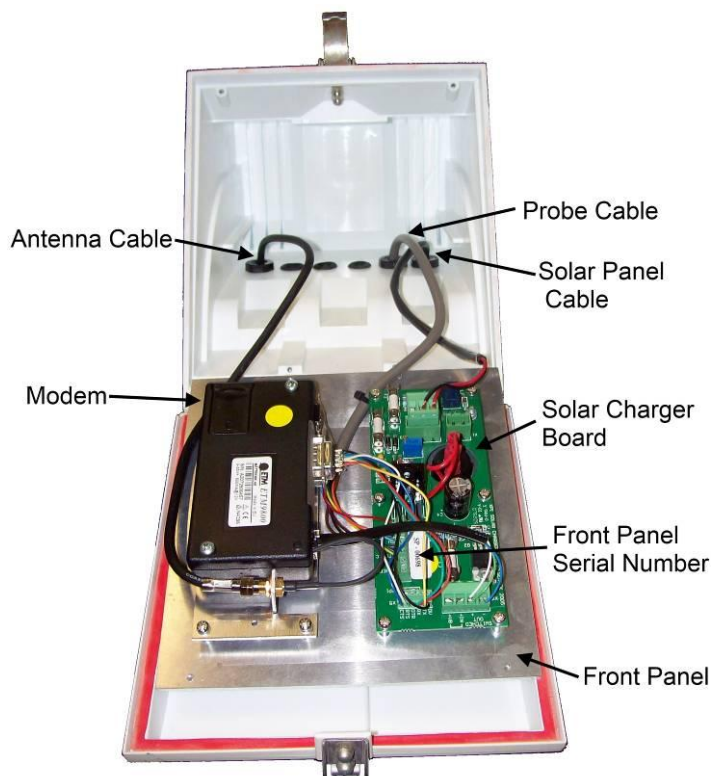

Figure 4 Sentek PLUS DTU housing

5. Insert the supplied 12v battery, with terminals facing towards rear of DTU, and connect it to the Front Panel
6. Screw the Sentek PLUS Front Panel into the DTU enclosure



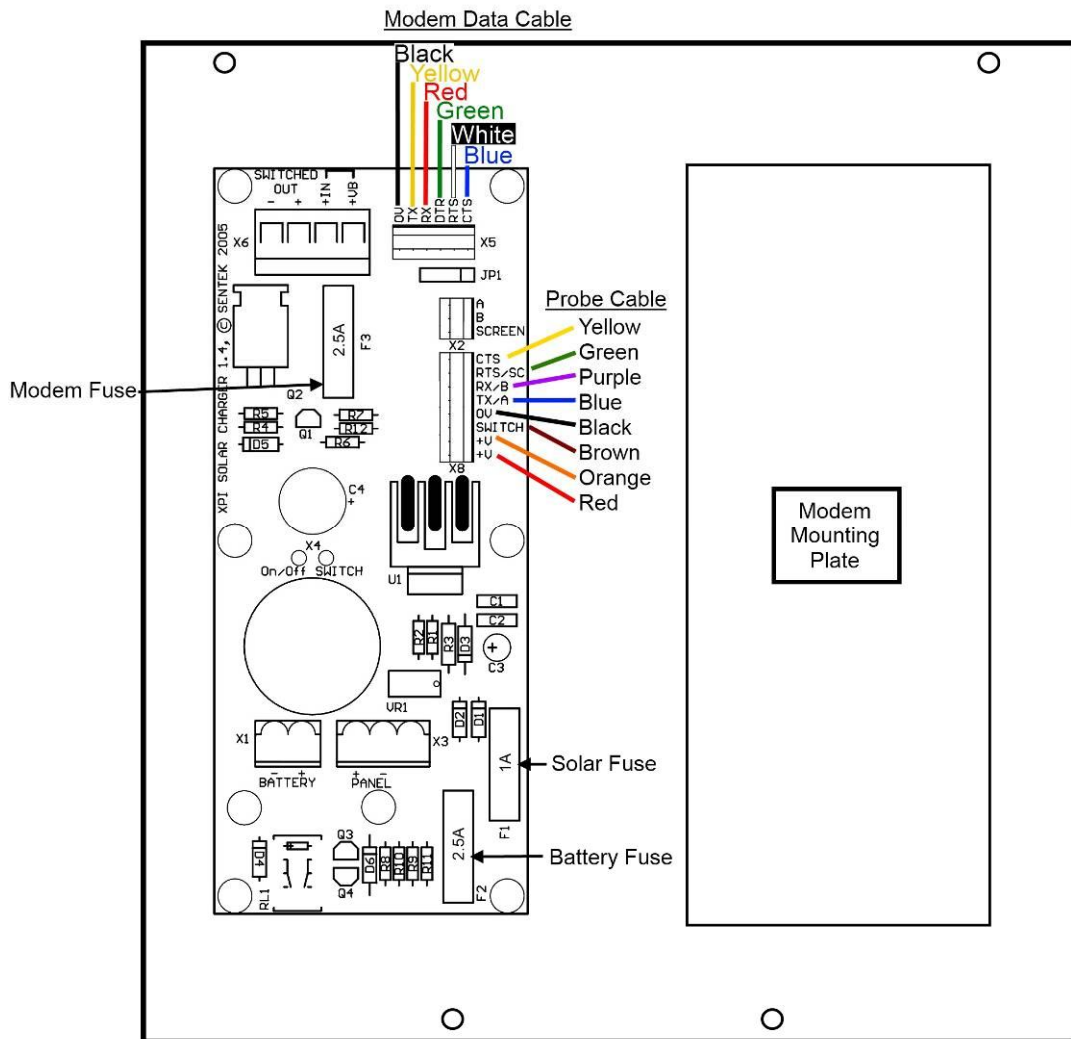

Figure 5 Rear of Sentek PLUS Front panel showing charger and Modem layout

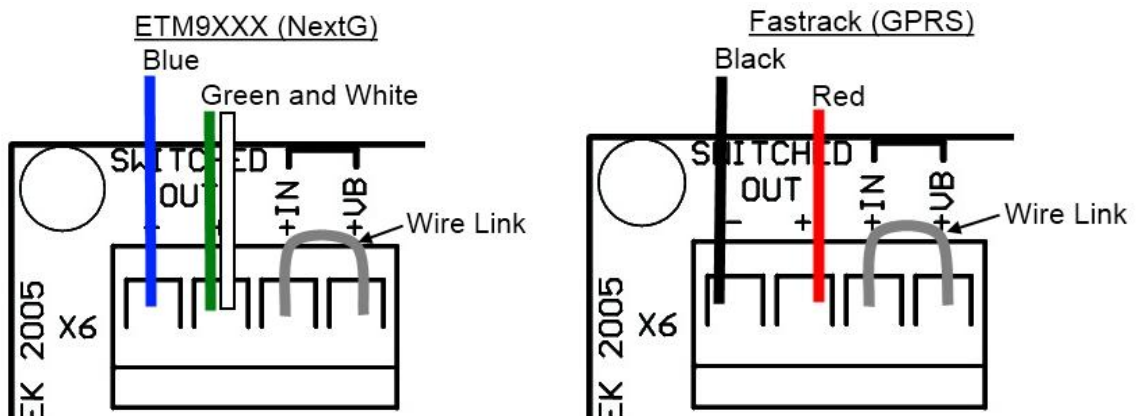

Figure 6 Modem power cable connections

**Note:** When using the DTU battery to supply power to the modem, the Wire Link should be firmly secured in place so that +IN and +VB are joined together.

## SENTEK PLUS PROBES

---

### Introduction

---

Sentek PLUS probes are configured using the Sentek software Probe Configuration Utility (PConfig) version 1.7.2 or later. The most recent version of PConfig is always available for download on the Sentek website. This hardware manual should be used in conjunction with the PConfig Help file.

Either EnviroSCAN or EasyAG probes can be used in a Sentek PLUS system. EnviroSCAN probes can be either Flat Cap or Screw Cap and the set-up steps will vary slightly between the two.

### Assemble and Normalise

---

1. Assemble EnviroSCAN probes according to the EnviroSCAN (Flat Cap or Screw Cap) assembly guides and as demonstrated during official distributor training. No assembly is required for EasyAG probes.

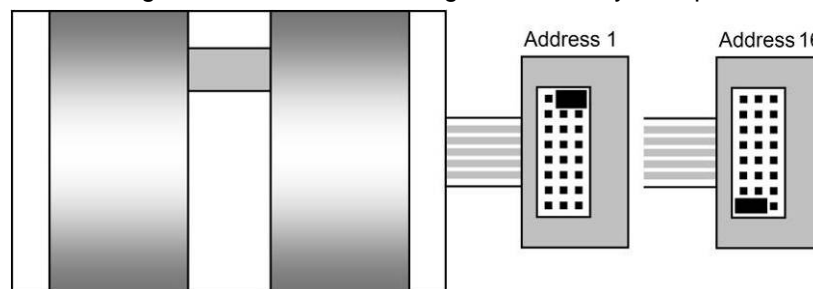

Figure 7 EnviroSCAN sensor addressing

2. Use PConfig to normalise each sensor on the probe. For detailed normalisation instructions, refer to the "Normalizing the Sensor Air & Water Counts" section of the PConfig Help file. More basic step-by-step instructions can be found further down in the section *Probe Configuration*.

**Note:** For best results, probes should be normalised using power supplied by the DTU, through the actual cable (with ferrite bead fitted) that is to be used in the field.

**Note:** Sensors placed in the very top position of the Flat Cap probe cannot be normalised in the standard Sentek normalisation container. Refer to the EnviroSCAN Flat Cap training guide for detailed instructions.

3. Label the probe and save back-ups of the normalisation on your computer.

### Install access tube and the probe

---

1. Install access tube as per the Sentek installation manuals (EnviroSCAN (Flat Cap or Screw Cap) or EasyAG) and as demonstrated during official distributor training.
2. Connect the cable to the interface. Cabling connections for the EnviroSCAN Flat Cap, Screw Cap and EasyAG probes vary, so the steps are broken up into three sections below. Follow the section relevant to the type of probe you are installing and ignore the other two.

### A. Install EasyAG probe

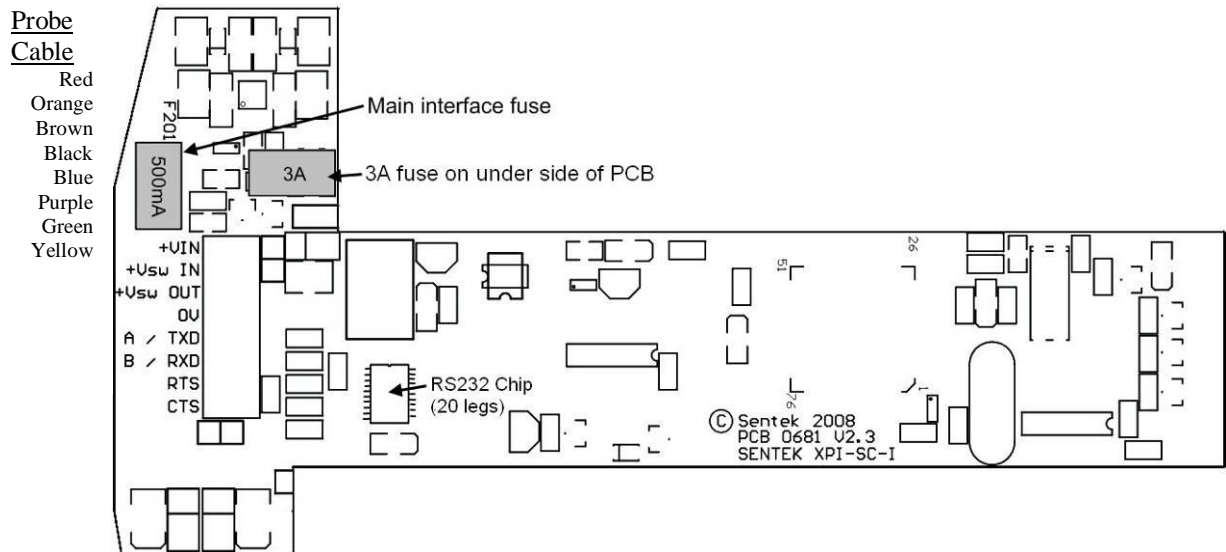

Figure 8 EasyAG PLUS interface and wiring diagram

- Slide the probe into the access tube.
- Insert the probe cable through the cable gland into the access tube, ensuring cable is looped around ferrite bead as near to cable gland as practical (see *Figure 2*). Tighten the cable gland on the cap with a spanner.
- Strip the outer grey sheath of the cable back, trim out the unused string, shielding and grey wire, and then strip about 10mm insulation from each remaining coloured wires.
- Twist the exposed copper wire and fold in half. Then fasten into the probe connector according to the diagram in *Figure 8*.

### B. Install EnviroSCAN Screw Cap probe

**Hint:** Insert cable into Screw Cap and wire into interface connector before gluing Cap onto the access tube to avoid compromising the glue seal.

- Insert the probe cable through the cable gland into the access tube, ensuring cable is looped around ferrite bead as near to cable gland as practical (see *Figure 2*). Tighten the cable gland on the cap with a spanner.

**Hint:** Pull enough cable through into the Screw Cap so that it can wrap around the handle (see *Figure 10*).

- Strip the outer grey sheath of the cable back, trim out the unused string, shielding and grey wire, and then strip about 10mm insulation from each of remaining coloured wires.
- Twist the exposed copper wires and fold in half. Then fasten into the probe connector according to the diagram in *Figure 9*.

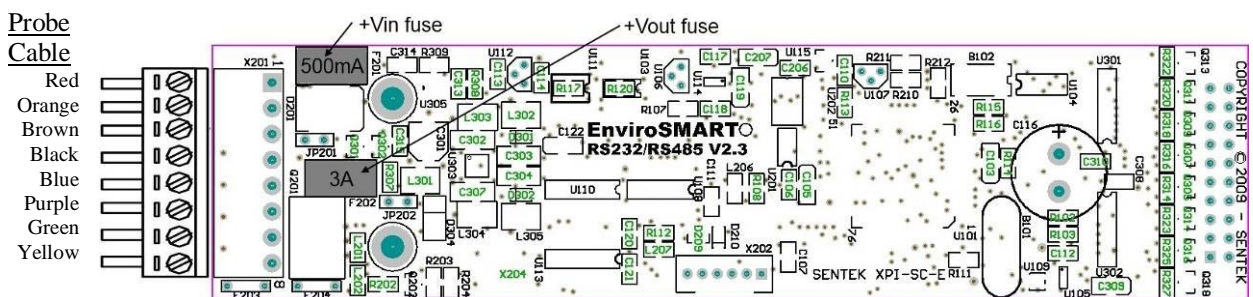

Figure 9 EnviroSCAN interface and wiring diagram

- Insert the probe into the tube and plug the connector in.



Figure 10 Probe sitting correctly in tube with connector in place

- e) Insert a silica gel bag through the probe handle and screw the lid onto the cap, taking care not to tear the bag or leave any overhang where the O-ring in the lid will make contact.



Figure 11 Gel bag

- f) Screw the lid onto the top cap assembly

#### C. Install EnviroSCAN Flat Cap probe, Attach Internal Cable

- a) If not already done, run internal cable down through the sensors on the back of the probe rod
- b) Loop the cable through a ferrite bead as close to the interface as possible
- c) Screw each wire of the internal cable into the interface connector according to the diagram in *Figure 9*.

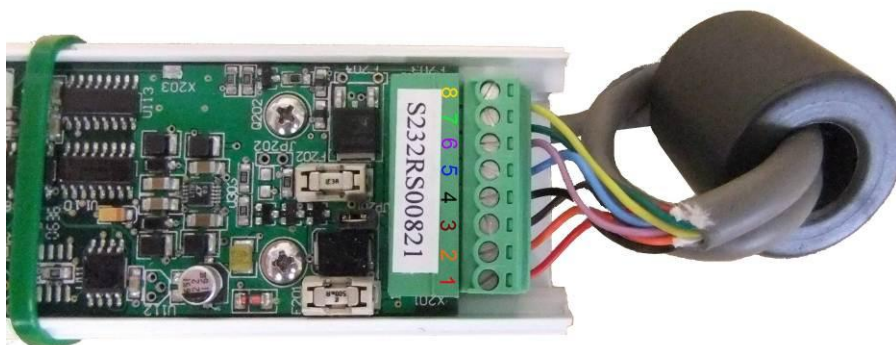

Figure 12 Flat Cap interface wiring

- d) Fold a silica gel bag and fasten it to the probe rod, just above the interface



Figure 13 Silica gel bag placement

- e) Plug the other end of the internal cable into the Flat Cap and attach the Cap to the probe

**Hint:** To completely test the Sentek PLUS EnviroSCAN Flat Cap probe, the TTL connector on the probe interface must be accessible. Therefore; the Flat Cap can be left out of the tube until final testing is complete.

- f) Insert the probe into the access tube, push the Flat Cap on until it clips into the access tube groove and then fasten it in place with the Herbie™ Clip.  
g) Fit the Sentek PLUS Probe Cable Connector to the Flat Cap cable.



Figure 14 Sentek PLUS Probe Cable Connector (Probe cable side)

- i. Use the assembly tool to unscrew the Insert Retaining Ring and remove the Contact Insert

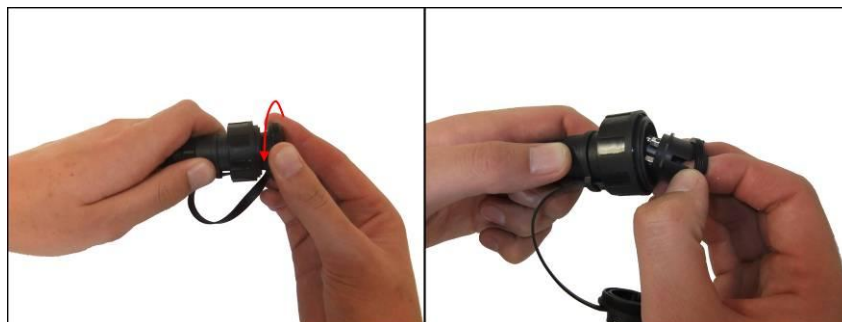

Figure 15 Removing Contact Insert

- ii. Unscrew the Gland Nut and ensure that the gland is the white (5-7mm) version and not black. The White Gland has a smaller inner diameter and therefore forms a better seal around the cable. Replace the Gland in the cage if necessary. Re-insert the Gland, Cage and Nut.



- iii. Insert the bare end of cable into the Gland Nut and push it right through to the other side of the Flex Body Moulding.



Figure 16 Inserting cable through Gland Nut

- iv. Strip 30mm of the outer (grey) cable sheath from the end and then 5-6mm of insulation off each coloured wire. The earth wire, grey wire and string can be trimmed back, as they are not used.



Figure 17 Trimming wires

- v. One-by-one, insert each of the 8 wires into the Contact Insert Screw Terminals and screw them in. Use *Figure 18* to determine the correct wiring order.

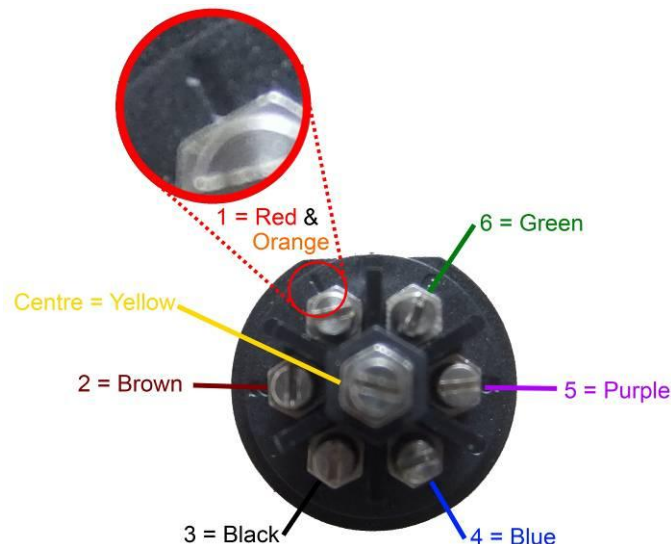

Figure 18 Contact Insert Screw Terminals

- vi. Pull the cable back through the Flex Body Moulding to re-seat the Contact Insert.
- vii. Ensure that the flat edge on the Contact insert lines up with the flat edge inside the Flex Body Moulding. Keep it in position by holding pressure on the cable while screwing the Retaining Ring back on. Use the back of the Assembly Tool to tighten the ring.

**Warning:** Failure to keep the flat edges together will cause the connector not to attach properly to the DTU cable connector and may lead to moisture damage of the connector, probe and/or DTU.

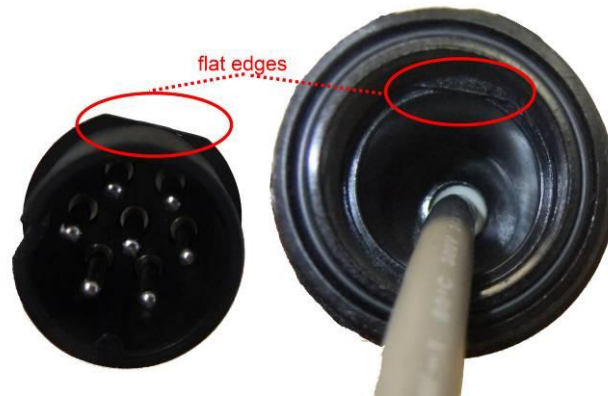

Figure 19 Flat edges

- viii. Tighten the Gland Nut with a spanner and cover it with silicone to seal the end up completely

**Hint:** To avoid making a mess with the silicone, use a fast drying silicone and wait until the entire Sentek PLUS system has been fully assembled and tested before applying the silicone.



Figure 20 Sealing gland end

**Note:** An alternative to installing the connector directly onto the Flat Cap cable is joining the cable to a complete Sentek PLUS connection cable. Wires should be joined with Scotchlok UR2 connectors and then housed inside a valve box. Full joining instructions can be found in the EnviroSCAN Flat Cap installation manual.

**Note:** The cable distance from the interface to the DTU must be kept to 5 metres or less.

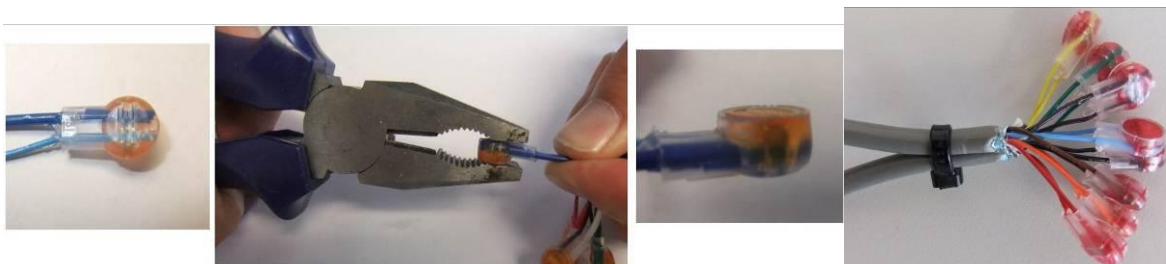

Figure 21 Cable joined using Scotchloks

### Cable probe to DTU

*These Steps are relevant for all three probes types (EasyAG, EnviroSCAN Screw Cap and Flat Cap)*

1. Run the cable back to the Sentek PLUS DTU, ensuring that it is protected from potential machinery or vermin damage and connect it to the DTU cable connector.
2. Now that the probe is connected to the DTU, the DTU can be switched on so that the probe is powered up.

## Probe Configuration

### Introduction

Before installing a Sentek PLUS system in the field, the probe must have the following configured:

- Ø number of sensors detected and depths set
- Ø air and water counts normalized
- Ø sampling interval set
- Ø clock synchronized
- Ø Sentek PLUS specific settings (explained in detail below)

Some applications may also require configuration of the Calibration Equation constants and Power settings, although the default settings are usually sufficient.

Each of these procedures will be explained in the order that they should be performed. Additional information can be found in the Probe Configuration Utility manual.

### Connecting to probe

The Sentek PLUS probe can be configured using either the DTU Front Panel connection or the probe interface TTL port. However, there are some limitations in using the Front Panel connection, such as; not being able to use any features that utilise the modem. Therefore, it is recommended that the probe TTL port is used.

The USB Probe Programming Cable (PConfig Cable) is used to communicate through the TTL port. Drivers for this cable must be installed before the cable is connected to the computer. Instructions on how to install the cable drivers can be found in Sentek Technical Brief *TB069-PConfig USB cable driver installation instructions*.

1. Use the Probe PConfig Cable to connect the TTL port of the interface to your computer.
2. Open PConfig,
3. Select the serial port that has been assigned to the cable
4. Select the baud rate of the interface TTL port (default = 9600)
5. Ensure that the DTU is switched on and press **Connect**. The PConfig software should now establish communications with the probe.

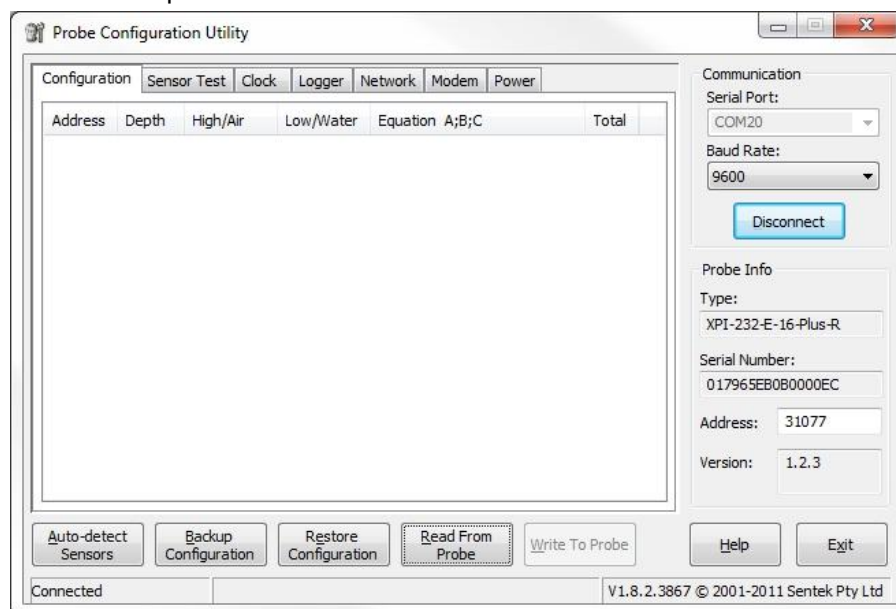

Figure 22 PConfig connected to probe with default settings

### Configuration page

1. Use the **Auto-detect Sensors** button to populate the sensor list in the Configuration page.



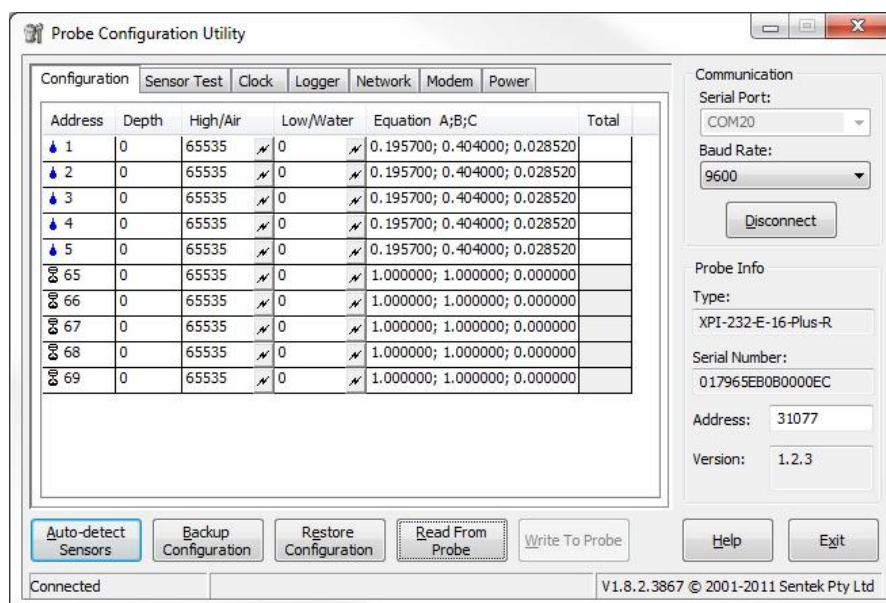

Figure 23 Auto-detected sensors

- Set the depth of each sensor by clicking inside each cell within the Depth column and changing the number by either clicking the up and down arrows or by typing it on the computer keypad. Sensors with addresses from 65 – 80 will automatically update depths once all other configuration information has been entered and written.

**Note:** TriSCAN sensors display as two sensors in the Configuration page. The moisture sensing function will be addressed according to the jumper settings on the sensor (i.e. 1-16). The VIC function also depends on the physical addressing of the pins, but range from 65 to 80 (where physical address 1 = 65 and 16 = 80)

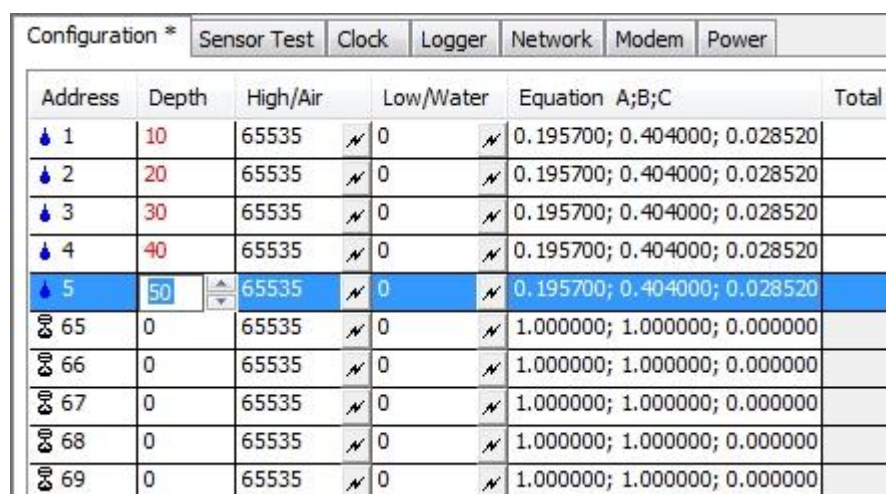

Figure 24 Setting depths

- To obtain the High (Air) counts for each sensor; place the probe inside its access tube. Then ensure that there are no obstacles (i.e. hands, cables, soil, tables etc.) within the sensor's sphere of influence (keep >20cm radius clear) and click on the header row of the High/Air column so that the interface takes a reading from each sensor.

**Note:** Alternatively, the Air counts can be taken one sensor at a time by clicking on the lightning bolt next to each sensor

- To obtain the Low (Water) counts, fill your Normalisation Container with water, slide the probe into the access tube until the first sensor is in the middle of the container. In the Low/Water column click on the lightning bolt in the corresponding row of the sensor being read. Repeat for each sensor, and remember to take a Water reading for both moisture and VIC when normalizing TriSCAN sensors.

**Important:** VIC water counts must be taken in reverse osmosis (RO) water (EC less than 300 $\mu$ Scm-1). Always normalise sensors under the same conditions to ensure maximum repeatability.

Configuration *							Configuration *								
Address	Depth	High/Air	Low/Water	Equation A;B;C			Total	Address	Depth	High/Air	Low/Water	Equation A;B;C			Total
1	10	36907	0	0.195700; 0.404000; 0.028520				1	10	36907	24624	0.195700; 0.404000; 0.028520			
2	20	37241	0	0.195700; 0.404000; 0.028520				2	20	37241	25049	0.195700; 0.404000; 0.028520			
3	30	36932	0	0.195700; 0.404000; 0.028520				3	30	36932	25464	0.195700; 0.404000; 0.028520			
4	40	36853	0	0.195700; 0.404000; 0.028520				4	40	36853	25251	0.195700; 0.404000; 0.028520			
5	50	35919	0	0.195700; 0.404000; 0.028520				5	50	35919	24834	0.195700; 0.404000; 0.028520			
65	0	20759	0	1.000000; 1.000000; 0.000000				65	0	20759	14107	1.000000; 1.000000; 0.000000			
66	0	20812	0	1.000000; 1.000000; 0.000000				66	0	20812	13670	1.000000; 1.000000; 0.000000			
67	0	20793	0	1.000000; 1.000000; 0.000000				67	0	20793	13983	1.000000; 1.000000; 0.000000			
68	0	21736	0	1.000000; 1.000000; 0.000000				68	0	21736	13811	1.000000; 1.000000; 0.000000			
69	0	21772	0	1.000000; 1.000000; 0.000000				69	0	21772	13508	1.000000; 1.000000; 0.000000			

Figure 25 Air counts and then Water counts

- If required, enter custom calibration coefficients for each sensor. Each coefficient should be separated by a semicolon (i.e. A;B;C). See the Calibration Manual for more information.
- Save (write) these settings to the probe by clicking **Write to Probe**. The Configuration page is complete

### Clock page

- Click on the Clock tab to display the clock settings. Decide how often the probe should take a reading and set the desired sampling interval accordingly.
- Set the probe clock to the desired time (usually probe local time) by either typing it in or synchronizing it with your computer clock.

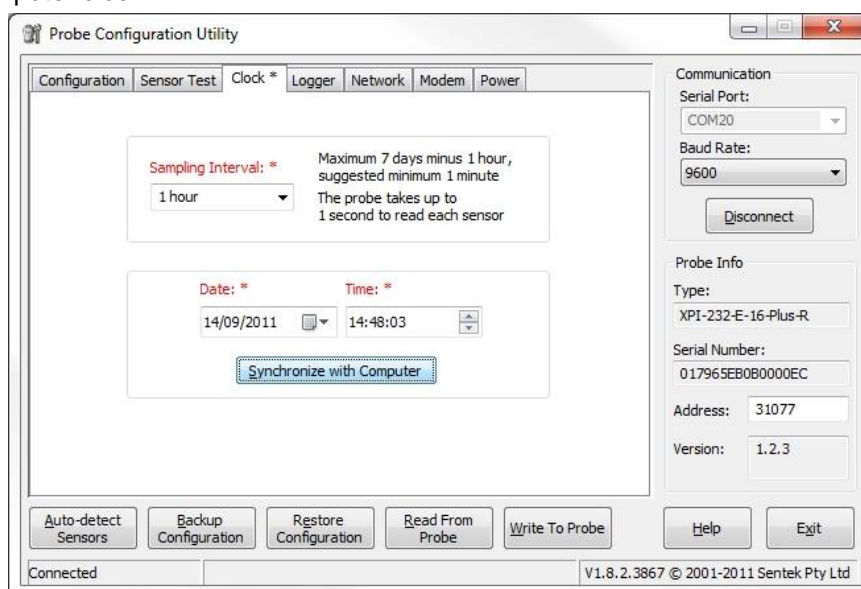

Figure 26 Clock page

- Write to Probe

### Logger page

In PConfig versions earlier than 1.8.1, the "Logger" page was named "Plus/Solo". If the "Logger" page does not appear when you are connected to the probe, either you do not have the latest version of PConfig, or the interface does not have the correct firmware loaded on it.

- Click on the **Logger** tab to display identification, uploading, and modem communication details.
- Type in a **Logger ID** specific to the probe so that the data can be identified later. This name is used to supply the IriMAX database Logger ID. The default is the probe's serial number. The logger ID can be up to 16 alpha-numeric characters and underscores and cannot contain any spaces.
- Set your desired **Sample Origin**. This determines when the first reading will be taken by the interface. All subsequent readings will use the Sample Origin as a starting reference. I.e. if the Sample Interval is 1 hour, and the Sample Origin is midnight, but the probe is only switched on at 7:05am, the first reading will occur at 8:00am, then 9am, 10am etc.
- Set the **Sample Count**. For a Sentek PLUS probe, this is the number of samples taken before an upload is initiated. A value of zero disables the upload process. For information on minimizing data costs, see the section *Buying a SIM card and data packet plan for modem*.

5. Set the **Dial-in Uptime**. This is the amount of time that the telemetry will remain enabled after each upload. Using Sentek Remote Connection Manager (RCM) software, during this time it is possible to dial-in to the modem or other telemetry connected to the probe. This allows the Probe Configuration Utility or Data Exchange to remotely connect to the probe.  
The uptime is counted from the beginning of the upload – for example, if the upload is at 12.00pm, takes one minute, and the Dial-in Uptime is set to 5 minutes, RCM can connect remotely to the probe between 12.01 and 12.05, although attempting to connect very near the beginning or the end of the dial-in interval may fail.  
If Dial-in is changed or disabled (Uptime set to 0) while connected remotely, this will not take effect until after the Probe Configuration Utility is disconnected.  
For information on how to dial into a probe, see the RCM Help file.

**Note:** if the upload takes longer than the Uptime, the Dial-in functionality will not be activated.

6. To complete the **Destination URL** field, click on the **Edit** button and enter in the FTP server details. Alternatively, the full URL can be typed in without going into Edit. The format of the URL is:

ftp://<user name>:<password>@<host/Internet address>/<url-path>

Your FTP server administrator should provide this information. If the URL is blank the upload process is disabled. For more information, see the section *Hosting Set-up and Recommendations*.

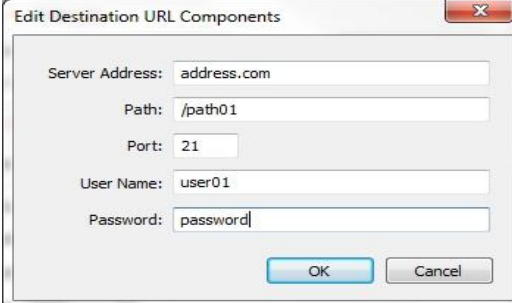

Figure 27 Edit screen

7. Set the **Connection Timeout**. This is the maximum time (in seconds) allowed from the start of an upload until communications with the FTP server are established. If this time is exceeded the upload attempt is abandoned. The default of 60 seconds is generally sufficient. Altering the Network settings may affect this.
8. Set the **Response Timeout**. This is the maximum time in seconds before the probe abandons waiting for a reply confirming that data has been transferred to the server. The default of 30 seconds is generally sufficient, but some connections (e.g. slow server responses) may require a larger value.
9. Set the **Baud Rate** and **Parity** to match the modem port communication settings. GPRS and NextG Modems supplied by Sentek are preconfigured to the default of 9600 baud and no parity, the probe settings must match this for them to communicate with each other.
10. Press the **Delete Readings** button to delete any unwanted data that may have been recorded before the probe was installed.

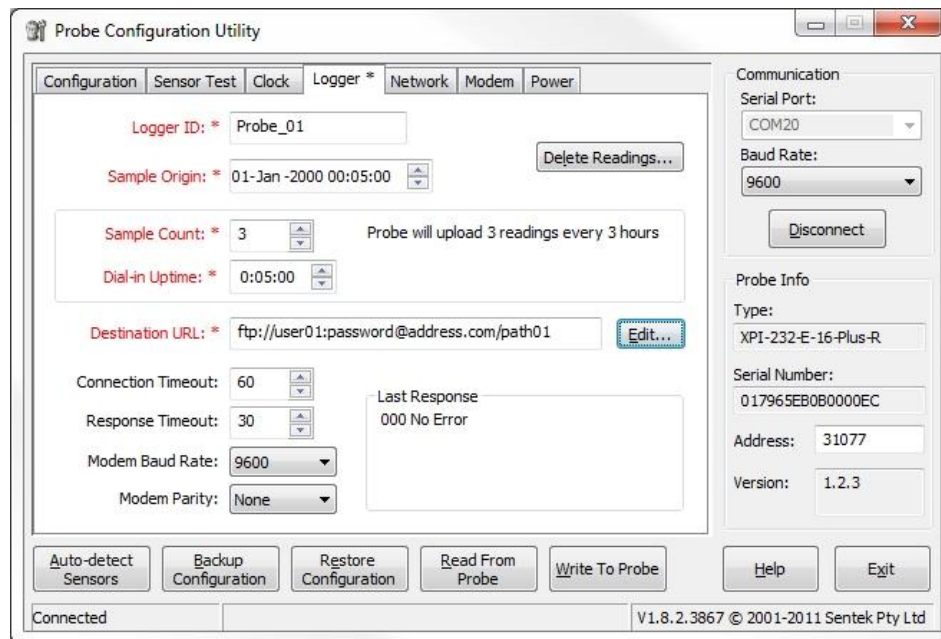

Figure 28 Completed Logger page

#### 11. Write to Probe

**Note:** the Last Response field is explained in section *Appendix E – PConfig Response Fields*.

#### Network page

The Network settings page contains command strings needed to prepare the modem, connect to the internet and shut the modem down properly.

The Network Access fields allow entry of a Username and Password if this is required by the mobile network service provider.

The Command Strings fields dictate the communications sent between the probe and modem. The fields on the left contain commands that will be sent to the modem (AT... commands), as well as command switches that control the behaviour of the probe (\... & |). The fields on the right are the responses expected from the probe. When a Response from the modem matches any of the expected responses the probe will move to sending the next command.

For more information on the upload process and how the Network settings are used, see section *Appendix B – Network page explained*.

1. Ensure that you are using the latest available Network settings for the modem that is on the DTU.

**Note:** Latest Network settings are available on the official Sentek web site underneath the PLUS product category in the Downloads section. Distributors will be notified whenever there is a change made to the recommended settings and are encouraged to keep copies of each settings file on their field computer.

- a) Ensure that you have written any unsaved changes to the interface and then press the Restore Configuration button at the bottom of the screen.
- b) Browse to the folder on your computer where you have saved the Network configuration files.
- c) Select the file which matches your modem and press Open. The files will be named by the modem type and have the file extension ".cfg".
- d) PConfig will display a warning, saying that there are no sensors in the configuration file, press OK.



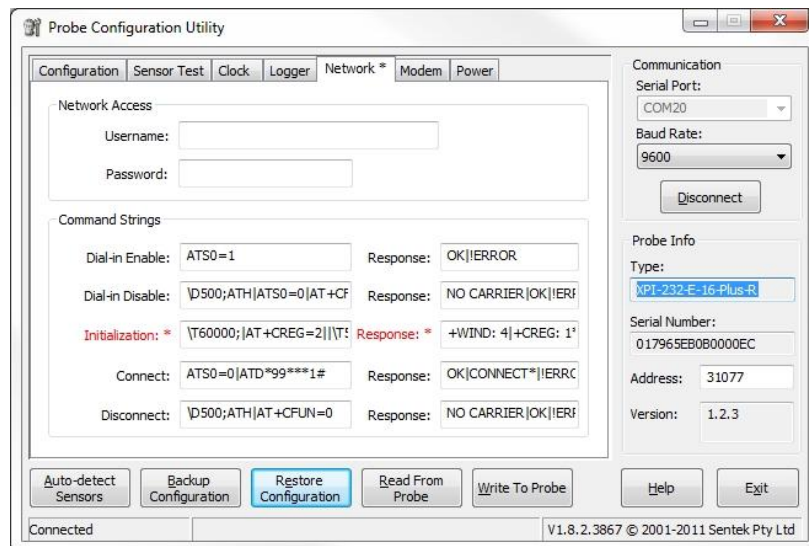

Figure 29 Network settings (with no unwritten changes)

2. If there are any changes, **Write to Probe**.

### Power page

1. Click on the Power tab to display the power related settings on the interface.

Operating Thresholds do not need to be changed from the default values. For advanced users, each field is explained below.

**Disable Probe** is the voltage at which the probe will shut down and stop logging.

**Enable Probe** is the voltage at which the probe will start up and begin logging again, after the voltage has dropped below the Disable Probe level.

**Disable Telemetry** is the voltage at which the probe will stop attempting to use the modem.

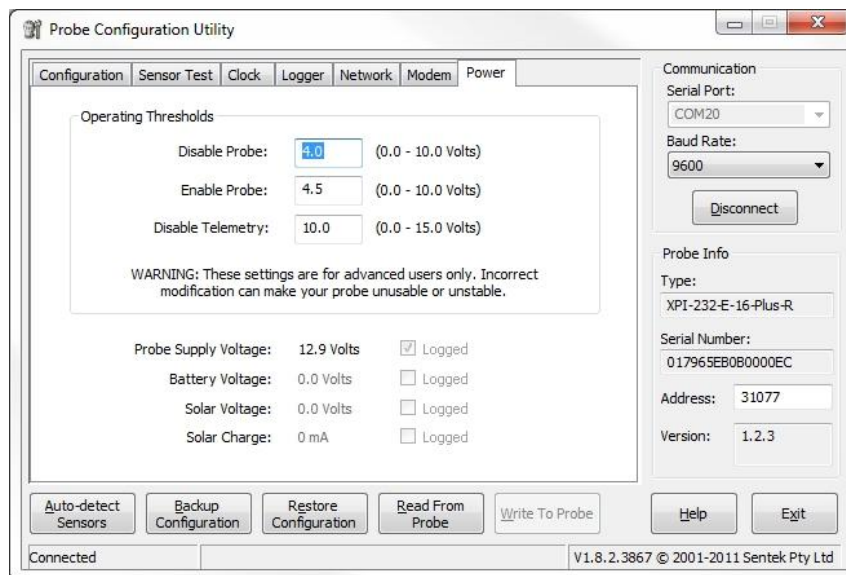

Figure 30 Power settings

2. If there are any changes, **Write to Probe**.

## MODEM CONFIGURATION

**The Modem page in PConfig is used to communicate with the modem, test the upload functionality, and manually upload any data that may be on the probe interface.**

The steps below include instructions on how to configure the modem for your chosen service provider. To ensure smooth operation, these steps should be followed during every Sentek MULTI set up;

**Note:** Modems are programmed and tested in Australia. This testing can only be done with a local network service provider. Therefore modems are sold with settings specific to that service provider

1. Whilst still connected in PConfig, click the Modem tab to display the modem communications and upload options.
2. Click **Open Session** to initiate communications with the modem. This will power the modem and allow you to send communications directly to it.

Commands can be sent to the modem by typing in the AT Commands field and pressing send. The commands will be echoed in the Modem Response field as well as any communications received from the modem. Sending a simple "AT" should get a response of "OK", indicating the probe can successfully communicate with the modem. Some messages will be preceded by a "\*\*\*" - these are messages generated by the probe, during communication with the modem.

**Note:** Modems can take up to a minute after power up before they are ready to process commands. Sentek configured modems will display a message (i.e. +WIND: 4 for Fastrack modem) when the modem reaches this stage of readiness.

**Note:** If a SIM is PIN enabled (that is if the modem requires a PIN upon start-up), the PIN must be entered in the modem before some commands are accepted by the modem. To enter the PIN, send "AT+CPIN=XXXX".

3. Set the correct frequency band for the service provider.  
By default, Sentek supplied ETM modems are set to auto select, and should not need to be changed. The Fastrack modem is set with the command "AT+WMBS=n" (where n = the band select value). For all possibilities of "n", see section *Appendix A – Modem information*. For information about which frequency band to use, consult your service provider.
4. Set the service provider's Access Point Name (APN).  
This is set with the command AT+CGDCONT=1,"IP", "<APN>", where <APN> is replaced with the correct APN supplied by the service provider. For details about which APN to use, consult your service provider.

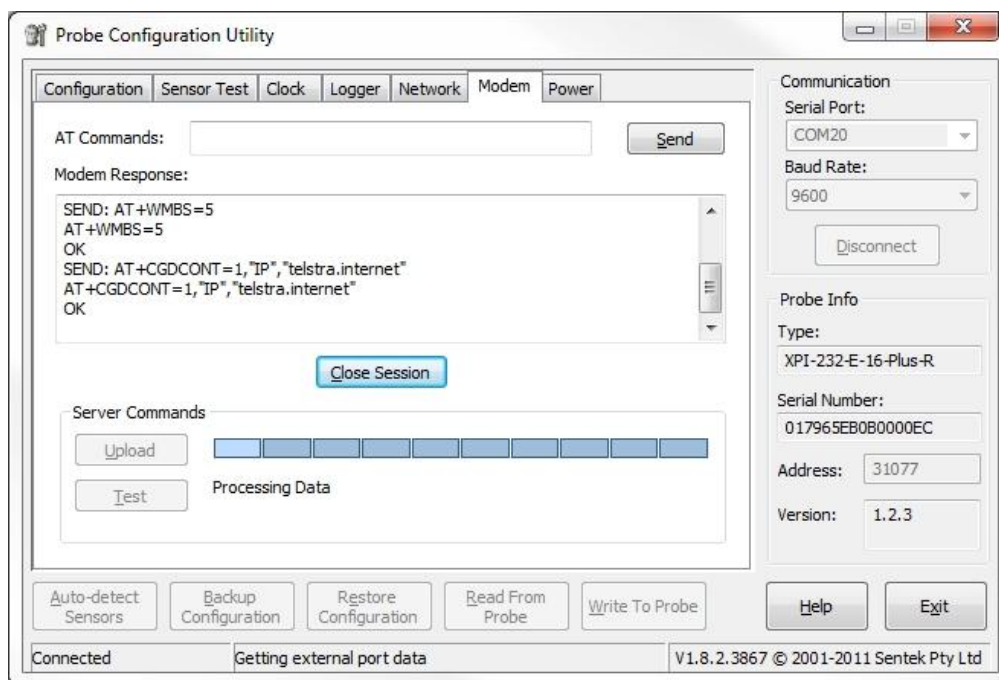

Figure 31 Sending modem settings (Response from a Fastrack modem shown above).

## TESTING

This is the most important stage of the setup process. If successful it will indicate that all preceding steps have been completed correctly.

1. Whilst still connected in PConfig, test the operation of the Sentek probe sensors by clicking **Query All Sensors** on the Sensor Test page. With the probe correctly **configured and installed** there should be no INVALID readings for Calibrated Values of individual sensors (Ignore the "Total" row).

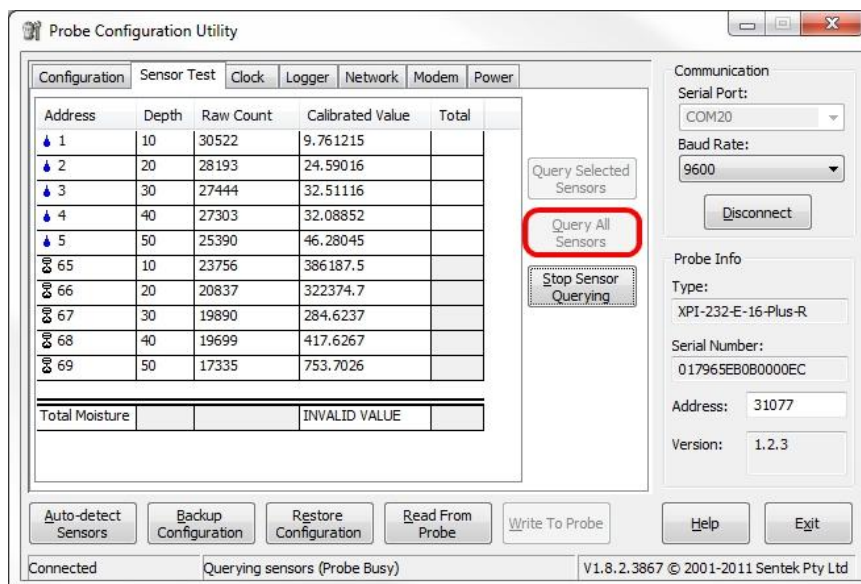

Figure 32 Sensor testing

- On the Modem page, press **Test** to initiate a test upload. This will simulate an upload, but instead of sending data in the form of .esp files, it will send a .txt file to the server. The end response in the Server Commands field should be "040 Success". This test will check all settings related to the modem as well as communications between it and the probe.

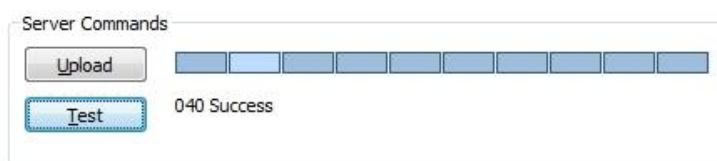

Figure 33 Successful Test

- Create a backup of the probe settings on your computer by pressing the **Backup Configuration** button and then selecting a folder and file name for it. The backup will be saved with a ".cfg" file extension.  
**Caution:** The backup files contain the destination URL and do not have any form of coding on the password. Please keep the files in a safe place if data security is a concern.
- In PConfig, press **Disconnect**. Physically disconnect the cable from the DTU and shut the lid on the enclosure.

If setting up downloads and graphs on the customer's computer immediately after testing, it may be beneficial to upload any data stored on the probe to the server by pressing the **Upload** button. Any readings taken since the last upload (scheduled or user initiated) will be uploaded.

**Note:** Once readings have been uploaded to the FTP server, they are deleted from the probe memory.

## VIEWING DATA

At this stage data should already be uploading, in the form of ".esp" files, to the ftp server specified in the probe configuration. To view the data it must first be downloaded to a local drive available to the computer. This is done using the Irrimax utility program Data Exchange (DEX). The data can be downloaded directly into ".csv", ".txt" or ".xls" format for viewing with a text editor or within Microsoft Excel. However Sentek recommends that for maximum benefits to be achieved from the data, Sentek's Irrimax software should be used for viewing data. To view the data in Irrimax it must be downloaded into ".sdb" format.

### Downloading

Each probe will require a separate download and database.

Any computer which is required to download the data must have Irrimax 7 or later installed.

It is recommended that the installer configures the downloads in a way that the end user can easily repeat them without risk of download settings being changed and/or data being stored in the wrong location. FTP server settings are saved in Data Exchange (DEX). Command line switches allow the DEX download process to be run from a script (or batch file).

Please refer to the Data Exchange Help file for information on downloading and running operations from command lines.

**Hint:** IrriMAX (using DEX) requires the details of the FTP server where the data is being stored. These details will be the same as what is entered in the probe, in the Destination URL field. Copy the details before leaving the probe site.

## Viewing

---

Graphs can be created with the IrriMAX software, using the information stored in the databases (.sdb files).

It is recommended that the data is made easily available for the end user. Graphs should be organized into IrriMAX Workspaces that can be accessed by the end user without it requiring them to know where the graph and workspace files are saved on the computer. To do this, shortcut icons for the workspaces (.sws files) should be created on the customers desktop.

For further information on how to create, manipulate and save graphs, refer to distributor training notes and the IrriMAX Help documentation.



## MAINTENANCE

---

Sentek PLUS Distributors can provide a regular maintenance program which consists of regular visits by an authorised installer to test and ensure correct operation of the system. A regular maintenance program such as this will ensure that the Sentek PLUS system functions properly and continues to give worry free operation.

## DTU

---

Regular maintenance of the Sentek PLUS system should consist of cleaning of the DTU to ensure dust and grime is kept to a minimum, especially around all seals.

The DTU and probes should be checked regularly for insect infestation. Some insects can cause low resistance between wiring tracks on the circuit boards which can cause intermittent or unreliable operation.

## PROBE

---

The probe top caps should be checked regularly for cracks or breakages. Machinery should be kept well away from the probes. This will avoid damage to the probe rods as well as avoid compaction of the soil around the probe, which can give a false indication of the soil moisture content

If problems are experienced, running tests may assist in determining any system faults. Consult the section *Appendix H - Sentek Plus Quick Reference Guide* for further details.

## SOLAR PANEL

---

Keep solar panel clean at all times. Clean with water and dry with soft cloth. A commercially available glass cleaner can be used for stubborn stains.

Regular checks on the orientation and angle of the solar panel should be performed. Winds, birds etc. can move the panel from its ideal position reducing its efficiency. If birds are a problem a "Bird Scarer" can be fitted to top of solar panel.

## CABLING

---

Corroded, shorting and broken wires can affect the operation of the equipment. Regular inspection of the cabling for damage from insects, animals or machinery should be carried out. If necessary the cabling can be elevated or buried away from potential damaging elements.

Exposed cable should be protected by some form of conduit.

## SLA BATTERY

---

The Sealed Lead Acid (SLA) battery supplied with the Sentek PLUS has a typical life expectancy of 1 to 3 years. The life of the battery is affected by number of discharges, depth of discharges and operating temperature. When the battery does not hold charge (causing loss of data at night) it will require replacing. Use the IrriMAX software to monitor the condition of the battery.

## PROBE CABLE CONNECTOR

---

The connector which is located between the DTU and probe is rated to IP68 for its dust and water resistance ability when installed and connected correctly. The connector will lose its water resistance when not used correctly.

Be sure that the two halves of the connector are pushed flat all the way together before screwing them together to avoid cross threading the locking ring. This will be obvious if there is any uneven gap visible where the locking ring meets the other side of the connector.

Ensure sealing caps are used on each connector when the probe has been disconnected from the DTU.

Screw sealing caps together when they are not in use. Doing this will keep the connector sealed while disconnected and prevent the rubber O-rings from falling out or becoming brittle.

The back of the sealing cap tool can be used to remove and fasten the Insert Retaining Ring to facilitate in field repairs.

The Gland Nut can be loosened and fastened with a 17mm spanner.

Once the gland nuts have been loosened they might not seal as well as they originally did. Therefore **Sentek strongly recommends covering them in silicon** or a similar product to help prevent moisture intrusion.

## FIRMWARE AND BOARD TYPE

Sentek PLUS requires a Sentek RS232 logging interface with Sentek PLUS/MULTI firmware installed on it.

### BOARD TYPE

Some variations of Sentek interfaces (boards) are very similar in appearance, but it is important to use the correct interface board for the application. Only RS232 logging interfaces can be used in Sentek PLUS systems. *Figure 34* shows how a suitable EnviroSCAN interface can be identified. *Figure 36* also shows another way of identifying the interface board type. EasyAG interfaces should be identified using the method shown in *Figure 35*.



Figure 34 EnviroSCAN RS232 logging interface

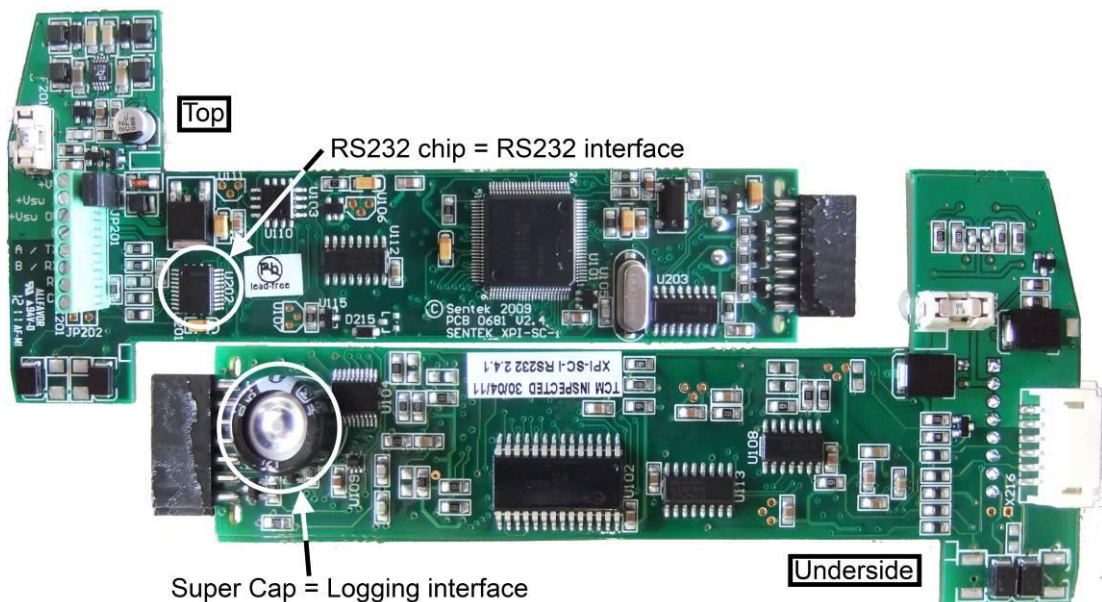

Figure 35 EasyAG RS232 logging interface

Logging interfaces can be identified by the Super Cap (C116) at the bottom of the interface, only the logging versions of the interface have this component installed. This Super Cap is located on the underside of the EasyAG RS232 logging interface.

RS232 interfaces will have the RS232 (U202) chip installed.

## FIRMWARE

It is recommended that the latest firmware version available from Sentek be used where possible. This means that when installing a new probe or servicing an existing probe, the firmware on the probe interface should be checked and updated if there is a newer version available.

Different versions of firmware have different default Network and Logger settings. This is important to remember when performing troubleshooting and/or replacing components on a system.

The current version of firmware will always be available on the Sentek web site; in the download section. For instructions on how to update the probe firmware, please read the Readme file included in the firmware download, as this contains full instructions.

The most accurate method of determining whether you have the correct type of interface and firmware is by using the PConfig software to connect to and read the interface. Figure 36 shows where this information is displayed in PConfig.

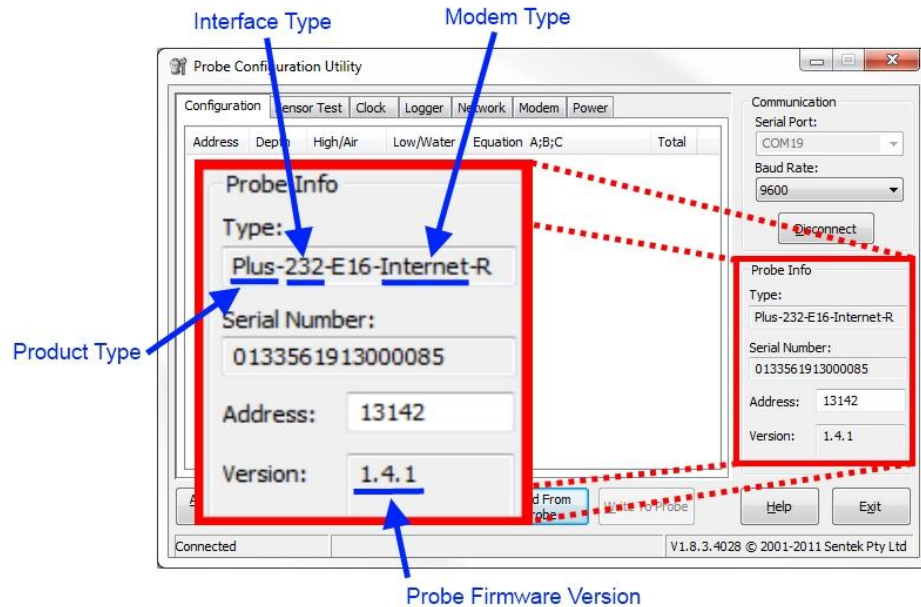

Figure 36 Checking probe type and firmware versions

## APPENDIX A – MODEM INFORMATION

---

### COMPATIBLE MODEMS

---

Sentek PLUS firmware version 1.2.3 introduced the ability to customise the various strings used to control the modem. As well as allowing certain parameters to be re-configured to suit the area in which a system is installed, this has the potential to allow any device that has a serial port and supports dial-up networking to be used with Sentek PLUS systems.

Sentek currently supplies and supports one modem for GPRS networks and one for Telstra's NextG network and pre-configures Sentek PLUS interfaces for their use. The recommended modem specific settings for the probe can change and it should not be assumed that the settings in the probe interface are correct. Files which contain the most recently recommended settings can be downloaded from the Sentek website. For more information on how to restore these settings, see section *Probe Configuration*.

Sentek is not obliged to provide support for modems which it has not supplied or agreed to support.

### ETM PACIFIC ETM9800 MODEM

---

The performance of ETM9800 modems containing firmware version 1 may be improved by installing the latest firmware. For further information see "TB064-ESPlus NextG Fails Network Selection" and "TB065-ESPlus NextG SIM PIN".

### SIM CARD PIN CODES

---

If the SIM card to be used in the modem is PIN locked, it can be unlocked using a mobile phone or by asking your provider to do so.

Alternatively, the Sentek PLUS interface may be set up to with the PIN in the Initialization string. This is the same as having to enter a PIN into a mobile phone when it is turned on, and gives some added security. To do this, when selecting the Network settings (.cfg) file to restore to the probe, select the file name which matches your modem and has the "PIN" identifier at the end of the file name (i.e. GPRS\_Fastrack\_PIN.cfg). Then, in the Initialization string on the Network page, replace the "XXXX" with the four digit PIN that is locking the SIM. Write the changes to the probe.

For example;

Initialization string for a Fastrack modem, with no SIM PIN enabled:

```
\T50000;|\T5000;AT+CREG=2||AT&D2|AT+CSQ|AT+CCED=0,1|AT+ADC?
```

With PIN enabled configuration file restored:

```
\T50000;|AT+CPIN=XXXX||\T5000;AT+CREG=2||AT&D2|AT+CSQ|AT+CCED=0,1|AT+ADC?
```

For SIM with PIN of "1234":

```
\T50000;|AT+CPIN=1234||\T5000;AT+CREG=2||AT&D2|AT+CSQ|AT+CCED=0,1|AT+ADC?
```

**Note:** The response string would also need to change in this example, because after power up, the modem does not report the "+WIND: 4" indication until after the PIN has been entered. So for the initialization process to begin, "+WIND: 1" must be added as an acceptable response.

Be aware that some ETM9800 modems were supplied with ETM firmware v1.10 which will not work with a SIM that is PIN locked. For more information about this refer to Sentek Technical Brief "TB065-ESPlus NextG SIM PIN".

### USEFUL AT COMMANDS

---

Below is a list of modem commands and descriptions on how to use them. These are just a small selection of the possible modem commands, but have proven to be most useful for use in the Sentek PLUS and MULTI systems. For full lists of commands, please contact the modem manufacturers.

These commands can be sent to the modems in the PConfig program, by pressing **Open Session**, typing commands in the **AT commands** field and pressing **Send**. The sent commands and the modem responses will appear in the Modem Response field.

Table 2 Modem Commands

Command	NextG (ETM9xxx)	GPRS (Fastrack)	Response
AT	Yes	Yes	Should return "OK"
AT+CSQ	Yes	Yes	Shows the current signal strength and service quality in the form "+CSQ: 22, 0". The first number shows the signal strength. A result of 99 indicates no signal, anything else over 14 is good. This number can vary considerably, and two or three readings should be taken to get a good indication. Consistent results of 99, or below 10 may indicate antenna problems or other connection issues. The second number can generally be ignored.
AT+CPIN?	Yes	Yes	Shows the PIN status of the SIM card. A response of "READY" indicates that the PIN has been correctly entered and the card is not PIN locked.
AT+CGDCONT?	Yes	Yes	Used to query the APN currently set in modem. Response should be in the form AT+CGDCONT=1,"IP",<APN>,"0,0 A value of 1,"IP",,,0,0 indicated the APN has not been set.*
AT+CGDCONT=1,"IP",<APN>	Yes	Yes	Used to set the APN for your service provider. Where <APN> is replaced with your service provider's APN. e.g. AT+CGDCONT=1,"IP","telstra.internet" *
AT^SCFG="Radio/Band"	Yes	N/A	Used to query the frequency band on which the modem will operate. See set command below.*
AT^SCFG="Radio/Band",n	Yes	N/A	Used to set the band on which the modem will operate. Where n has the following possibilities;  127 - auto select (from GSM 900, GSM 1800, WCDMA 2100 & WCDMA 850Mhz)  64 - UMTS 850Mhz (NextG)  1 - GSM 900  e.g. AT^SCFG="Radio/Band",127 Also see section <i>Extra Frequency Band information</i> *
AT+WMBS?	N/A	Yes	Used to query the band on which the modem will operate. See set command below.



Command	NextG (ETM9xxx)	GPRS (Fastrack)	Response
AT+WMBS=n	N/A	Yes	Used to set the band on which the modem will operate. Where n is replaced by one of the following possibilities;  0 - mono-band 850MHz 1 - mono-band mode 900 extended MHz (900E) 2 - mono-band mode 1800 MHz 3 - mono-band mode 1900 MHz 4 - dual-band mode 850/1900 MHz 5 - dual-band mode 900E (extended) / 1800 MHz 6 - dual-band mode 900E (extended) / 1900 MHz  e.g. AT+WMBS=4 Also see section <i>Extra Frequency Band information</i>
AT+WOPEN=0	N/A	Yes	Used to set the modem's internal TCP/IP stack to off. Note: Probes with firmware later than v1.1.4 handle TCP/IP stack on interface
AT+WIND?	N/A	Yes	Shows current WIND indication settings. This determines which WIND notifications are output by modem.
AT+WIND=511	N/A	Yes	Used to set correct range of WIND notifications that are output by modem.
<i>Unsolicited Response Codes (i.e. modem responses not initiated by AT command)</i>	N/A	Yes	+WIND:0 – SIM removed +WIND:1 – SIM inserted +WIND:3 – Ready to process some AT commands +WIND: 4 – Ready to process all AT commands +WIND:7 – Network service available for emergency calls +WIND: 8 – Network is lost
ATQ0	Yes	Yes	Used to set modem to display result codes
AT+WOPEN=0	N/A	Yes	Used to disable modem TCP/IP stack. Also see section <i>Older Sentek PLUS Systems</i>

\* SIM must be present to process these command

### Extra Frequency Band information

Modems will need to be power cycled (turned off and back on) before frequency changes will take effect. In PConfig, pressing Close Session, waiting a few seconds so that the modem can close down properly and then pressing Open Session will achieve this.

#### NextG (ETM9xxx)

**Note:** Some ETM modems may have the ability to utilise other frequency bands, such as the ETM9910-1, which can use the WCDMA 900 band. Please contact the modem manufacturer if you wish to use a band other than GSM 900, GSM 1800, WCDMA 2100 or WCDMA 850. This would only be necessary if using a service provider other than Telstra.

ETM9910-1 modems are preconfigured to AT^SCFG="Radio/Band",211, which covers all bands supported by the modem.

#### GPRS (Fastrack) Modem bands

**GSM 900 / GSM 1800 MHz** are used in most parts of the world, including: **Europe, Asia, Australia, Middle East, Africa.**

**GSM 850 / GSM 1900 MHz** are used in the **United States, Canada, Mexico** and **most countries of South America.**

There are some exceptions to this, so please consult your service provider if unsure.

Information sourced from worldtimezone.com, viewed at 26 July 2011,  
<<http://www.worldtimezone.com/gsm.html>>

## OLDER SENTEK PLUS SYSTEMS

---

Sentek PLUS systems previously running firmware versions 1.1.4 or earlier will require additional modem configuration to use firmware version 1.2.3 or later. Information in this section relates only to the GPRS Fastrack modems.

### Parity

---

Modems that were used with probe firmware 1.1.4 or earlier would most likely communicate with 'Odd' parity. Therefore; older probe configurations may be set to use 'Odd' parity to communicate with the modem. Newer modems have a default value of no parity (None). A mismatch of parity settings between the probe and modem will result in no communication between the two devices.

The probe parity setting should be altered to match the modem parity setting (see section *Probe Configuration*).

### TCP/IP Stack

---

Modems used with probe firmware 1.1.4 or earlier would have been configured with the on-board TCP/IP stack enabled. The TCP/IP stack on the modem must be disabled for use with probe firmware 1.2.1 or later. For information on how to turn the modem TCP/IP stack off, see Table 2.

Newer modems do not have on-board TCP/IP stack, but the command to switch it off can still be sent without affecting system operation.

### APN server

---

Modems which were using on-board TCP/IP stack (with probe firmware 1.1.4 or earlier) used the AT#APNSERV command to set the APN server. When the modem TCP/IP stack is turned off, the APN server should be set using the relevant command in *Table 2*.



## APPENDIX B – NETWORK PAGE EXPLAINED

---

**Username and Password** (Not used in Dial-in mode): These are for the GPRS or NextG network that the SIM card connects to – they are related to the APN server, not the FTP server. Many network providers allow these to be blank. For correct settings, contact your network provider.

The **Command strings** are used to control the modem during each stage of the Sentek PLUS system upload process. Sentek provides configuration files on the Sentek website to restore the network strings for modems sold by Sentek. Generally, the settings should not be altered from the default settings provided by Sentek in these files.

**Dial-in Enable:** In Dial-in mode, after every Sample Count interval has been reached the telemetry power is turned on and this string (up to 80 characters) is sent to the modem. The telemetry remains powered for the time specified in Dial-in Uptime, and then the Dial-in Disable string is sent. In normal (not Dial-in) mode, this string (up to 80 characters) is sent upon completion of an upload unless the Dial-in Uptime is set to zero – in this case, the dial-in feature is inactive.

This field can be used to command the modem to auto-answer incoming calls, for the uptime period, after the sample count scheduled time.

**Dial-in Disable:** In Dial-in mode, after a Dial-in Enable is sent, and when the end of the Dial-in Uptime has been reached, this string (up to 80 characters) is sent, and then the power is removed from the telemetry.

This field can be used to prevent the modem auto-answering incoming messages at times other than the sample count scheduled time.

In normal (not Dial-in) mode, this string (up to 80 characters) is sent before starting an upload. The Dial-in Enable is sent at the completion of the upload. The telemetry remains powered for the time specified in Dial-in Uptime, and then the Dial-in Disable string is sent.

If the Dial-in Uptime is zero the dial-in feature is inactive.

**Init String:** This string (up to 80 characters) configures the modem for communication, after it has been powered on.

**Connect:** (Not used in Dial-in mode) This string (up to 80 characters) supplied by your Network provider, is the command needed to connect to the network. It generally initiates the dialing of a specific telephone number.

**Disconnect:** (Not used in Dial-in mode) This string, up to 80 characters, is sent to the modem after the probe has sent the data to the network. It will disconnect the modem from the network.

**Response(s):** After being sent a command the modem replies with a response. If the specified response string is not received within the timeout period (\T...) set in the corresponding Network field, the will probe abandon communication until the next scheduled time. This includes responses that do not match the response string. The Dial-in Enable and Disable timeout is not dependent on the Connection Timeout value. A reply is considered matching when the start of the reply exactly matches the response string (up to 40 characters).

**APPENDIX C – UPLOAD OPERATION DIAGRAM**

Table 3 upload operation diagram

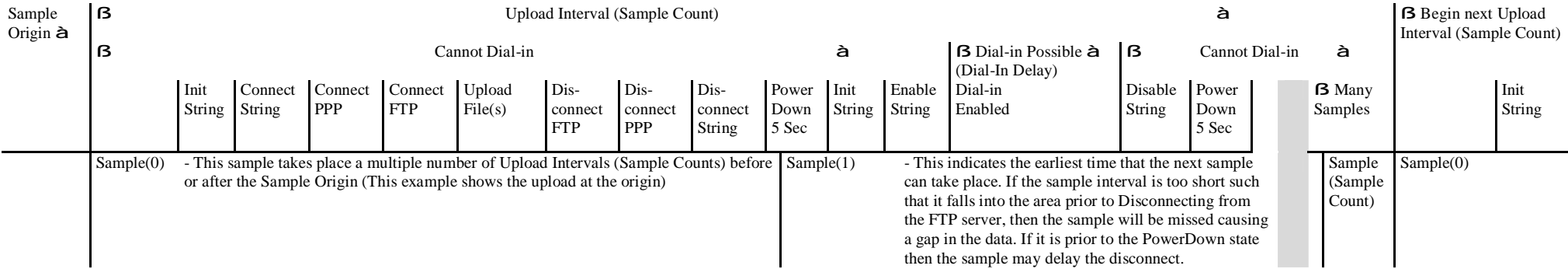

## APPENDIX D - ESTIMATED BATTERY LIFE WITH NO SOLAR PANEL

Due to the extremely low power requirements of a Sentek PLUS system it is possible to run the system for extended periods without a solar panel. The following formulas are intended to aid in estimating the operating time between recharges of a standard Sentek supplied battery when used with a Sentek PLUS system and no solar panel.

**WARNING:**

The following calculations are provided purely as an estimate, based on a "best case" operating scenario with standard Sentek parts. It should be noted that the actual life of the battery may be less than 50% of the estimate provided by the calculations. Factors such as ambient temperature modem signal strength and other unpredictable factors could have an adverse effect on the life of the battery.

Completely draining any sealed lead acid (SLA) battery can permanently destroy it. The calculations provided determine how long the system will run before the supplied battery is completely drained, running this long will destroy the battery.

The final calculation translates the life of the battery to how long before the battery should be recharged. The recharge cycle is only 70% of the life of the battery because SLA batteries can withstand 3x as many charge cycles if they never drop below 30% of their original capacity than they would if they were discharged to less than 10%.

The following table shows average power consumptions in various states for modems that have been shipped with Sentek PLUS systems

Modem Type	Connect Current	Upload Current	Dial-in Current (Modem & Probe)	Active Dial-in Current (Modem & Probe)
M1206B	20mA	70mA	35mA	105mA
M1306B	30mA	80mA	35mA	105mA
Supreme	35mA	60mA	35mA	125mA
ETM9800	80mA	165mA	65mA	155mA
CDMA	155mA	190mA	--	--

## CALCULATING THE BATTERY LIFE

The below calculations will provide the estimate of battery life. The supplied values are in milliamp-seconds (mA.s). For the purposes of the calculations, each TriSCAN sensor counts as one moisture sensor and one salinity sensor.

<b>Power Used For Salinity</b>	60 x Salinity Sensors x Samples per Day
<b>Power Used For Moisture</b>	45 x Moisture Sensors x Samples per Day
<b>Awake Power</b>	70 x Samples per Day
<b>Power Connecting To Network</b>	30 x Modem Connect Current x Uploads per Day
<b>Power Connecting to FTP</b>	30 x Modem Upload Current x Uploads per Day
<b>Power Talking To Modem</b>	4000 x Uploads per Day
<b>Dial-in Power</b>	Dial-in Current x Dial-in time (seconds) x Uploads per Day
<b>Total Power Per Day (mA.s)</b>	Add up all of the above results
<b>Life Of Battery (Days)</b>	25,200,000 ÷ Total Power Per Day

<b>Recharge Cycle (Days)</b>	0.7 x Life Of Battery
------------------------------	-----------------------

Note that the rating of the Sealed Lead Acid Battery provided by Sentek is 7 Amp hours, which converted to milliamp-seconds is  $(7 \times 60 \times 60 \times 1000) = 25,200,000 \text{ mA.s}$

Active Dial-in sessions - the time spent connected to the probe with the Probe Configuration Utility using the dial-in capability - are not likely to significantly affect power consumption.

**Example:**

Consider a Sentek PLUS system with a Wavecom *Supreme 20* modem and 6 TriSCAN Sensors that samples every 15 minutes and uploads 4 times a day, leaving the modem open for dial-in for 10 minutes after each upload. Suppose that the Probe Configuration Utility is used to connect to the system remotely for around 10 minutes, no more than once every 50 days.

This gives the following initial values:

Modem Connect Current:	35mA
Modem Upload Current:	60mA
Modem Dial-in Current:	35mA
Modem Active Dial-in Current:	125mA
Salinity Sensors:	6
Moisture Sensors:	6
Samples Per Day:	$24 \times 4 = 96$
Uploads Per Day:	4
Dial-in Time:	10 minutes = 600 seconds
Dial-in Session Time:	10 minutes = 600 seconds
Dial-in Sessions Per Day:	$1/50 = 0.02$

Using the above table, the calculations look like this:

		<b>Result</b>
<b>Power Used For Salinity</b>	$60 \times 6 \times 96$	34560
<b>Power Used For Moisture</b>	$45 \times 6 \times 96$	25920
<b>Awake Power</b>	$70 \times 96$	6720
<b>Power Connecting To Network</b>	$30 \times 35 \times 4$	4200
<b>Power Connecting to FTP</b>	$30 \times 60 \times 4$	7200
<b>Power Talking To Modem</b>	$4000 \times 4$	16000
<b>Dial-in Power</b>	$35 \times 600 \times 4$	84000
<b>Active Dial-in Power</b>	$125 \times 600 \times 0.02$	1500
<b>Total Power Per Day (mA.s)</b>	$34560 + 25920 + 6720 + 4200 + 7200 + 16000 + 84000 + 1500$	180100
<b>Life Of battery (Days)</b>	$25,200,000 \div 180100$	140 Days
<b>Recharge Cycle (Days)</b>	$0.7 \times 140$	98 Days

From these calculations, it should be clear that the Dial-in feature significantly affects power usage – for comparison, if the Dial-in time was set to 0 in the above calculations, the battery life would be 266 days, and the recharge cycle 186 days. For this reason, users running battery-only Sentek PLUS systems should carefully evaluate their requirements when considering enabling Dial-in.

## APPENDIX E – PCONFIG RESPONSE FIELDS

### LAST RESPONSE

The **Last Response** shown on the Logger page of PConfig is the result of the last attempt by the probe to upload to the destination URL. This upload attempt can be a scheduled upload (triggered by the **Sample Origin**), or a user initiated **Test** or **Upload** from the Modem page of PConfig. See below for more detail on these Responses.

### TEST/UPLOAD RESULT CODES

The 053 error in the example picture below was a result of the Connection Timeout period being reached before the connection to the FTP server was established (i.e. if the modem power cable was unplugged).

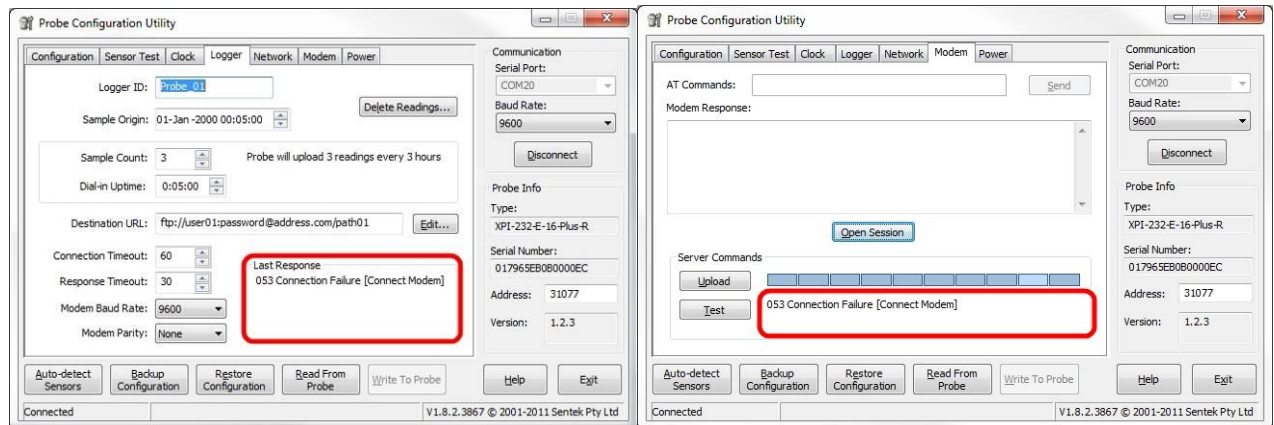

Figure 37 Upload result codes from most recent upload attempt

The table below shows a list of the response codes that may be seen during or after an upload attempt. The codes are separated into two sections; Progress codes indicate which stage of the upload process the probe is at. Upload response codes are used to show the result of an attempted upload.

Table 4 Last Response and uploading response codes

Code	Message Detail	Description
<b>Progress codes</b>		
000	No Error	Only occurs after first ever power on (No upload has been attempted)
001	Initializing Interface	Initialisation and connect strings being sent
002	Initializing FTP	Connecting to FTP server
003	Transferring	Transferring data
004	Uploading to Server	Uploading file/s to FTP server
005	Disconnecting from Server	Disconnecting from FTP server, APN server and shutting down modem
<b>Upload response codes</b>		
040	Success	Upload was successful (file transferred to FTP server)
041	Success (No Data)	No new data to upload
042	User Cancel	Pressed Cancel in PConfig
051	Clock Not Set	Clock needs to be reset (modify or re-sync with PC and write to probe)
053	Connection Failure	Modem not responding to commands, or could not connect to internet (see note below)
054	Server Error	Problem communicating with FTP server

<b>055</b>	<b>Internal Error</b>	Corrupt file in probe memory. Need to clear memory (Delete Readings)
<b>056</b>	<b>Front Panel Active</b>	Attempted to perform modem function while connected through Dial-in or Front Panel
<b>057</b>	<b>Supply voltage too low</b>	Voltage below Telemetry Disable level
<b>058</b>	<b>Invalid URL</b>	Destination URL invalid

**Note:** If test upload fails with the error “053 Connection Failure: "Error timeout" [Connect Modem]”, go to the Network tab of the Probe Configuration Utility and check the Initialization string. It should begin with “\T” followed by a number. This number indicates the time in milliseconds that the interface will wait for the initial modem response. Increasing it may correct this error – for example, changing it from “\T30000” to “\T60000”.

**Note:** If test upload fails with the error “053 Connection Failure: "Error timeout" [Connect Modem]”, it could be caused by the probe not seeing any of the acceptable responses within the timeout period set at the beginning of the Initialisation string (see section *Network page*).

In PConfig, measure the time it takes after clicking Open Session for each message to appear in the Modem Response field. The timeout at the beginning of the Initialisation string should exceed the time it takes for the first expected response to appear.

For example; the first expected response could be “+WIND: 4”, and this commonly takes anywhere from 15 to 40 seconds to appear after modem power up. So the initialization string should start with “\T50000;|”. This would mean that the modem has 50 seconds to display the +WIND: 4, if it’s seen the probe continues through to the Initialisation string. If it takes longer than 50 seconds (or doesn’t appear at all), the probe will timeout and abort the attempt.

## UPLOAD LOG

---

It is possible to retrieve from the probe, a log of the codes from the last upload attempt. Only the information from the previous upload test, whether it was a scheduled upload or user initiated Test, is kept in the log. To retrieve the logged upload information from the probe;

1. Connect to the probe in the PConfig software.
2. Go to the Modem page of PConfig
3. Press Open Session
4. Wait until the modem has finished sending the Unsolicited Result Codes and then, using the AT Commands field, send the command below:

`\showdetails`

The log information should be displayed in the Modem Response field. Copy all text in this field into a text editor program (i.e. Notepad). Save the information.

This manual does not attempt to explain how to interpret the \showdetails information. Sentek Distributors can send a copy of the response to Sentek for interpretation and troubleshooting help.



## APPENDIX F - TECHNICAL SPECIFICATIONS

---

### ENVIROSCAN SERIES II 232 INTERFACE

---

**PCB Revision:** REV 2.3  
**Identification Label:** XPI-SC-E-RS232  
**Interface connector type:** Brand: Phoenix Contact  
MC 1,5/8-ST-3,5 (Plug)  
MC 1,5/8-G-3,5 (Socket)

**RS232 Interface pin configuration:**

1. +Vin
2. +Vin(T)
3. +Vout(T)
4. Ground
5. TX – RS232 Data
6. RX– RS232 Data
7. Request to send (RTS acts as DTR in the Plus systems)
8. Clear to Send (CTS)

**Voltage Supply (RS232 +Vin):** 4 – 15 Volts (12 V DC @ >200mA recommended)

Fuse specifications: F201 Littelfuse 0154-500 (500mA fast blow)  
F202 Littelfuse 0154-003 (3A fast blow)

**RS232 Interface baud rate:** 1200, 2400, 9600 (default), 19200 or 38400 bits per second (user configurable)

**TTL Interface connector type:** Brand: JST  
B 6B-PH-K (Socket)  
PHR- 6 (Plug), SPH-002T-P0.5S (Crimp connectors)

**TTL Interface pin configuration:**

1. +Vcc
2. Transmit data (Tx)
3. Receive data (Rx)
4. Reserved
5. Reserved
6. Ground

**Voltage Supply (TTL +Vcc):** 5 Volts, supplied by the EnviroSCAN probe interface

**TTL baud rate:** 1200, 2400, 9600 (default), 19200 and  
38400 bits/second (user configurable)

**Total current consumption:** 400µA standby @ 12V DC  
105mA sampling (Moisture) @ 12V DC  
130mA Sampling (TriSCAN) @ 12V DC

**Time to sample 1 sensor:** 45 milliseconds maximum (Moisture only)  
90 milliseconds maximum (TriSCAN)

**Maximum sensors supported:** 16 Moisture Sensors or  
16 TriSCAN Sensors

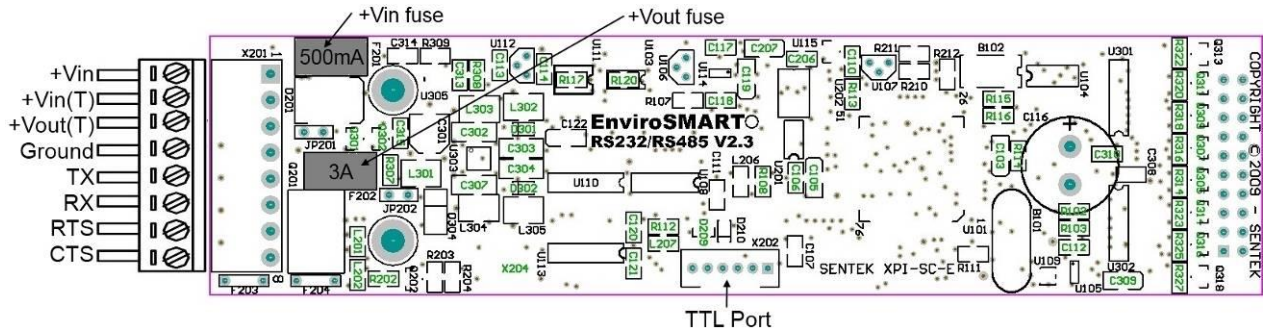

Figure 38 EnviroSCAN RS232 probe interface board layout

## EASYAG SERIES II RS232 INTERFACE

**PCB Revision:** REV 2.4  
**Identification Label:** XPI-SC-I-RS232L  
**Interface connector type:** Brand: Phoenix Contact  
MPT0.5/8-2.54

**Interface pin configuration:**

1. +Vin
2. +Vin(T)
3. +Vout(T)
4. Ground
5. TX – RS232 Data
6. RX– RS232 Data
7. Request to send (RTS acts as DTR in the Plus systems)
8. Clear to Send (CTS)

**Voltage Supply (RS232 +Vin):** 4 – 15 Volts

**RS232 Interface baud rate:** 1200, 2400, 9600 (default), 19200 and  
38400 bits/second (user configurable)

**TTL Interface connector type:** Brand: JST  
B 6B-PH-K (Socket)  
PHR- 6 (Plug), SPH-002T-P0.5S (Crimp connectors)

**TTL Interface pin configuration:**

1. +Vcc
2. Transmit data (Tx)
3. Receive data (Rx)
4. NC
5. NC
6. Ground

**Voltage Supply (TTL +Vcc):** 5 Volts, supplied by the **EasyAG** probe interface

**Fuse specifications:** F201 Littelfuse 0154-500 (500mA fast blow)  
F202 Littelfuse 0154-003 (3A fast blow)

**TTL Interface baud rate:** 1200, 2400, 9600 (default), 19200 and  
38400 bits/second (user configurable)

**Total current consumption:** 400µA standby @ 12V DC  
102mA sampling (Moisture) @ 12V DC  
126mA Sampling (TriSCAN) @ 12V DC

**Time to sample 1 sensor:** 45 milliseconds maximum (Moisture only)  
90 milliseconds maximum (TriSCAN)

**Maximum sensors supported:** 8 Moisture Sensors  
8 TriSCAN Sensors

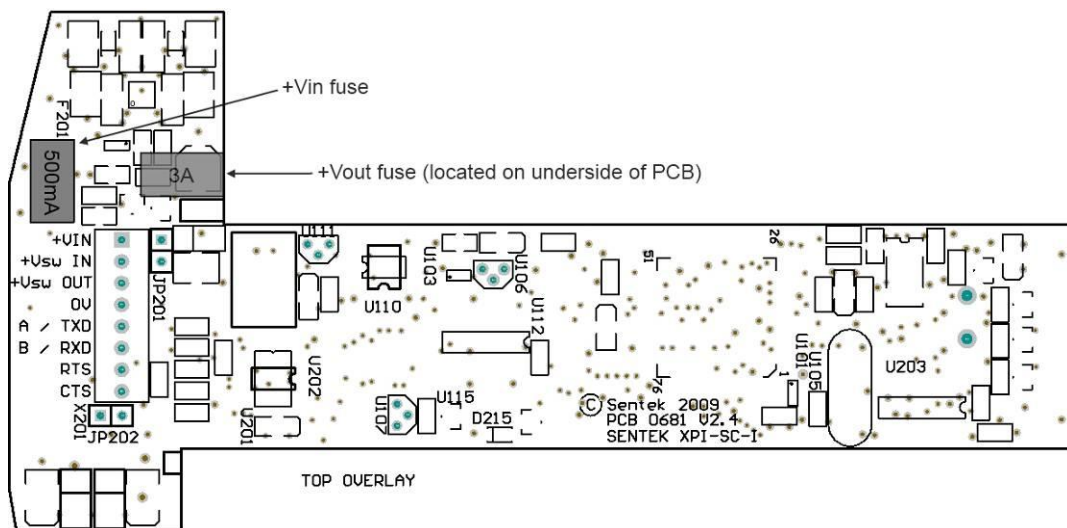

Figure 39 EasyAG Series II RS232 probe interface board layout

## APPENDIX G - GLOSSARY OF TERMS

---

3G	Third Generation mobile phone network
BW	Bandwidth, the amount of traffic allowed in a set period
CDMA	Code Division Multiple Access (Used by selected Modems)
Domain name	Name given to web location e.g. www.sentek.com.au
DTU	Data Transmission Unit (housing containing modem, battery and solar charger board)
FQDN	Fully qualified domain name
FTP	File Transfer Protocol – used to upload / download files
GPRS	General Packet Radio Service (Used by selected Modems)
Host	Web site / data storage provider
HTTP	Hyper Text Transfer Protocol - Used to download files
IP Address	Internet Protocol address – Numbered address of host
NextG	Telstra Australia implementation of 3G
PIN	Personal Identification Number
SIM Card	Subscriber Identity Module, required for GSM/GPRS/NextG Access
Storage Capacity	Available space on server to store data files
URL	Universal Resource Locator

## APPENDIX H - SENTEK PLUS QUICK REFERENCE GUIDE

This appendix is designed to be a short guide for installers of Sentek PLUS. It can be printed and carried into the field and act as a reminder for the basic steps needed to install and troubleshoot a complete Sentek PLUS system. It does not replace the manual, it merely supplements it.

### PRODUCT SET-UP CHECKLIST

#### Preparation

1. Select probe and DTU sites. Test signal strengths and decide on system configuration.
2. Organise data transmission and hosting, as detailed in Sentek PLUS Hardware Manual section *Data Transfer and Hosting*.
3. If practical, mount and wire-up DTU housing, solar panel and antenna onto a mounting pole prior to field installation.
4. Using PConfig, for each probe;
  - Check that the interface has the latest version of firmware
  - Configure sensors (Auto-detect, set depths & normalise)
  - Set Clock (Time & sampling interval)
  - Configure Modem Settings (Restore network configuration which matches modem being used)
  - Check system (Test)

(For further information, refer to Sentek PLUS hardware manual and PConfig Help)

**Warning:**  
Do not leave the 12V battery in the housing during transportation or damage may occur

#### Field Installation

1. Install access tubes and mounting poles as per the Sentek Access Tube Installation Guides (Flat Cap or Screw Cap), and as demonstrated during official Sentek training.
2. EasyAG and EnviroSCAN Screw Cap probes only, skip to step 3 for Flat Cap.
  - a) Insert the probe cable through the top cap cable gland into the access tube, ensuring cable is looped around ferrite bead as near to cable gland as practical and tighten the gland.

**Hint:** Insert cable into top cap before gluing it onto the access tube to avoid compromising the glue seal between the cap and the access tube.

- b) Strip the wires on the probe cable and connect them to the interface screw terminal (See Figure 40 and Figure 41).

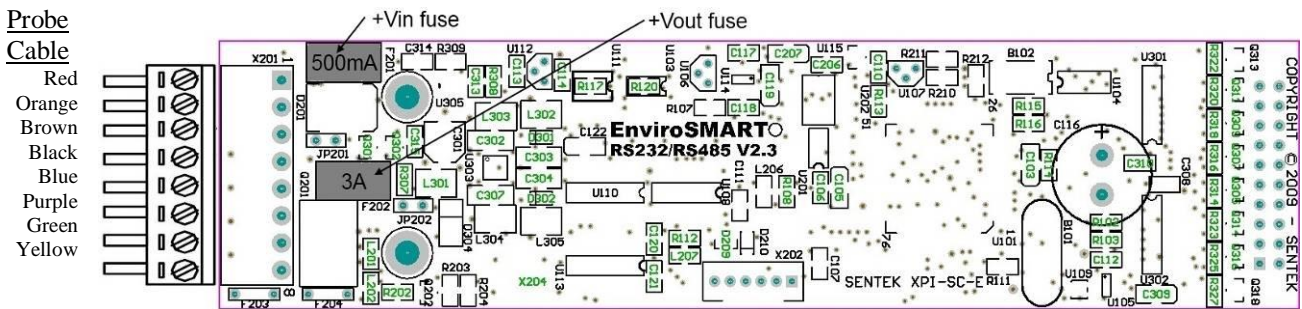

Figure 40 Sentek EnviroSCAN PLUS interface wiring

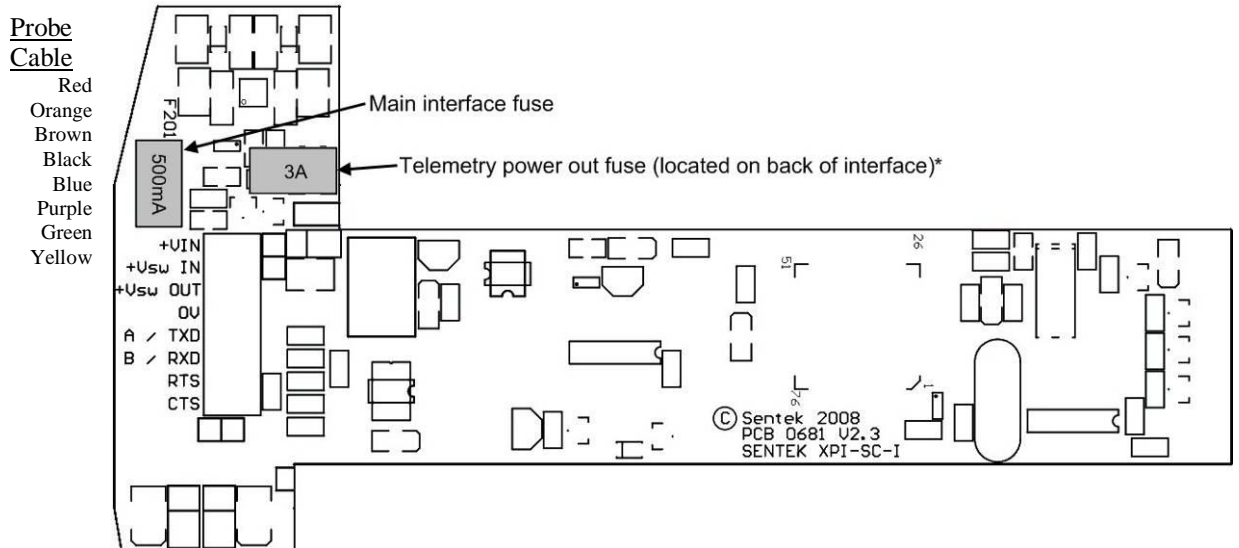

Figure 41 Sentek EasyAG PLUS interface wiring

3. Insert the probes into the access tubes.
4. Flat Cap probes only: Install the 7-pin quick connector on the Flat Cap cable and plug it into the DTU cable.
5. Connect the antenna, battery and then solar panel to the DTU.
6. Switch the DTU on, check the probe clock time and test the sensors. Then test the upload function of the probe.

## Software

Allow probe time to upload readings to the server.

1. Enter the server details into Data Exchange (Edit Server).
2. For each probe, use the New Database Wizard and Download Wizard within an IrriMAX workspace to set up new databases and associated downloads.
3. Create graphs, save the workspace and create a batch file to run the downloads.

**Example Batch File:** "Path to IrriMax.exe" "path to workspace.sws" /DOWNLOAD



## TROUBLESHOOTING GUIDE

Once a problem has been flagged, troubleshooting should be carried out in this order:

1. Download all data and review graphs, looking at all sensors for problem symptoms and causes.
2. Before picking up any tools, moving cables or altering the system in any way, connect to the probe in PConfig and identify what the current fault is. If you miss this step, you will not know whether you have fixed the original problem or not.

**Tip:** Upload readings and back up probe configuration before changing any probe settings.

3. Using Table 5 below as a starting point, begin finding the cause of the fault. Change only one thing at a time and then check to see if it has changed the original symptom of the fault. Try something else if the symptom has not changed.
4. Once the cause and symptom have been found and rectified, test all sensors and upload operation in PConfig. If a new symptom appears, start again at step 2.

**Tip:** Disconnect 12V battery and solar panel when servicing the DTU; this includes any wiring to the connectors or whenever the antenna is to be disconnected.

Table 5 Troubleshooting

Symptom/Error Message	Possible Cause of Failure	Check	Possible Solution
Cannot connect to probe with PConfig	Wrong COM Port selected in PConfig	Check COM Port number in Windows Device Manager	Ensure cable drivers are installed and correct COM port is selected
	Low power supplied to interface	Measure DC voltage at interface connector and DTU points X8, F2 & X1	Replace battery
			Replace corroded wires or connectors
			Re-strip and connect all wires
			Replace F2 fuse
	Power switched off	Check DTU power switch	Ensure switch is in the On (I) position
PConfig cable not connected	Visual check	Make sure cable is fully connected with TTL port on interface <b>Note:</b> The USB port supplied voltage cannot be used to power the interface	
Poor probe cable wiring at DTU or Probe (specifically power and ground wires)	Use Plus manual to check wiring configuration	Re-terminate all connections	

Symptom/Error Message	Possible Cause of Failure	Check	Possible Solution
	Blown (F201) interface fuse	Measure voltages at each end of fuse	Replace fuse (check wiring first)
Failure to "Test" upload	Modem not powering up with Open Session in PConfig	Should be >12V at either end of fuse (using Pin 4 as ground reference)	Replace F202 with 3A fuse
		Should be >12V at Pin 3 (brown wire) on interface	Replace Interface (if F202 fuse is good)
		Should be >12V at SWITCH Pin (brown wire) on X8 connector of DTU	Replace probe cable (if power is ok at interface)
		Should be >12V at either end of F3 fuse voltage on DTU (using battery negative as ground reference)	Replace F3 with 2.5A fuse
		Should be >12V modem supply voltage at X6 connector of DTU	Replace DTU panel or modem
	Probe settings	Check Network Settings	Download Network settings .cfg files from Sentek web site and restore correct file to probe
		Modem powers up (LED's light up) but doesn't communicate with probe in Open Session	Adjust Parity and Baud Rate in PConfig one at a time and check in Open Session after each change until probe communicates with modem.
		"053 Connection Failure [Connect Modem]" result code	Increase Connection Timeout in probe
	Poor wiring	Modem powers up (LED's light up) but doesn't communicate with probe in Open Session	Re-terminate probe and modem data cable connections
	Low voltage	Measure probe supply voltage (Pin1 - red wire)	Replace battery or probe cable if low
		Check Voltage in PConfig	Replace interface if voltage reading is wrong

<b>Symptom/Error Message</b>	<b>Possible Cause of Failure</b>	<b>Check</b>	<b>Possible Solution</b>
Failure to upload readings	Corrupt internal memory	"055 Internal Error" result code	Update firmware. See Sentek Distributor Forum for more detail
	No new data to upload	Try downloading manually	Allow probe to take some readings and check again before scheduled upload time
Data updating after download, but not up to correct time	Probe Clock incorrect	Check in in PConfig	Change probe clock to local time
Invalid sensor data (0 raw counts), but voltage readings ok	Interface pins not all in socket	Remove interface screws and check seating of interface	Re-install interface on probe (refer to EnviroSCAN probe assembly guide)

## RECOMMENDED MAINTENANCE SCHEDULES

---

### 6 months (or each time access tube is opened)

---

- Check probe and access tube for moisture
- Replace gaskets (EasyAG)
- Replace silica gels bag

### 12 months

---

- Check for dust and/or water ingress into DTU housing
- Check quick connector pins for signs of corrosion/moisture
- Check cable for damage to outer sheath and wires
- Check antenna is secured tightly
- Ensure all cables are neat
- Clean SIM contacts

### 3 years

---

- Replace 12V battery